

Constant Voltage drivers

Wiring Key Points

1. This product shall be installed by a qualified electrician.
2. Make sure the main power supply to the driver is turned off when wiring either the LEDs or driver.
3. LEDs shall be wired in parallel as shown in wiring diagram. CAUTION: incorrect wiring may damage LEDs.
4. Wire shall be #18AWG stranded minimum. Large gauge wire shall be used to limit voltage drop in order to maintain the proper operating voltage. Take every precaution to avoid interference from other electrical circuits and equipment.
5. Dimming circuits are more sensitive to voltage drop and electrical interference from other electrical sources.
6. Isolating LED wiring by dedicated circuit for each control zone is recommended.
7. Contractor shall verify the fixture quantities connected to the driver are compatible with the driver's specifications prior to energizing the circuit.
8. All Class II power cable remote wiring and driver enclosures by others.

LED's can be permanently damaged if these points are not followed

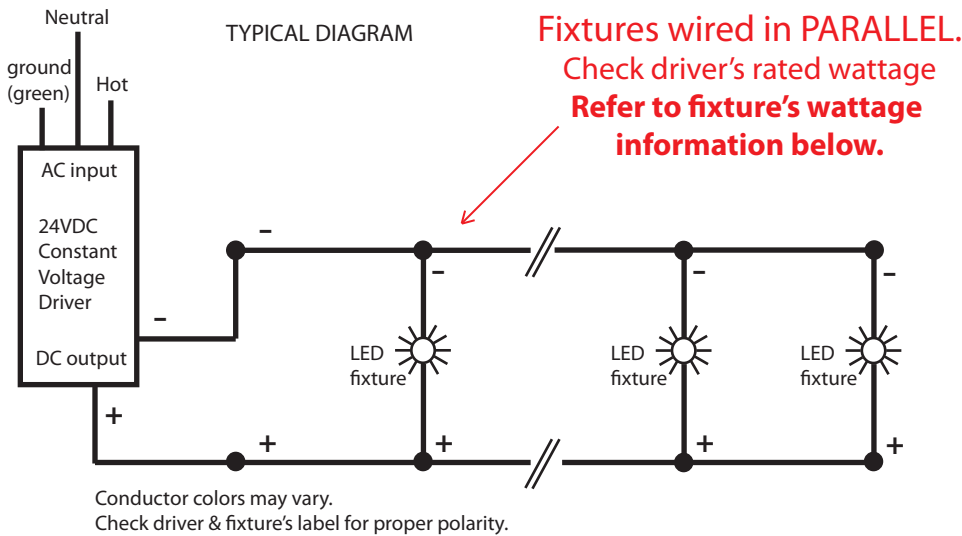

Maximum wiring distance*

Wire gauge	Load per driver		
	≤48W	≤72W	≤96W
#18AWG	37'	25'	18'
#16AWG	59'	39'	29'
#14AWG	95'	63'	47'
#12AWG	151'	101'	75'
#10AWG	241'	160'	120'

* Voltage drop guide for 24VDC. Actual Voltage drop to be calculated by installer.

Fixture

Nominal Length

Watts/fixture

PLEASE NOTE: LUTRON CONSTANT VOLTAGE DRIVERS REQUIRE A MINIMUM LOAD OF 5 WATTS

inter•lux

Project:	Type:	Date:
Manufacturer:	Fixture:	Page:

Hi-lume® A-Series Driver Overview EcoSystem® or 3-wire control

Hi-lume® A-Series Driver is a high-performance LED driver that provides smooth, continuous 1% dimming for virtually any LED fixture, whether it requires constant-current or constant-voltage. It is the most versatile LED driver offered today due to its compatibility with a wide variety of LED arrays, multiple form factors, and numerous control options.

Features

- Continuous, flicker-free dimming from 100% to 1%.
- Compatible with Energi Savr Node™ unit with EcoSystem®, GRAFIK Eye® QS control unit, PowPak® dimming module with EcoSystem®, and Quantum® systems, allowing for integration into a planned or existing EcoSystem® lighting control solution. Please see chart at the end of this document or contact Lutron for details regarding compatible controls.
- Standard 3-wire line-voltage phase-control technology for consistent dimming performance and compatibility with all Lutron® 3-wire fluorescent controls.
- Line voltage miswire protection on EcoSystem® control inputs.
- 100% performance tested at factory.
- A rated lifetime of 50,000 hours @ $t_c = 65^\circ\text{C}$.
- UL recognized for United States and Canada.
- FCC Part 15 compliant for commercial applications at 120 V \sim or 277 V \sim .
- Pulse Width Modulation (PWM) or Constant-Current Reduction (CCR) dimming methods available. See Application Note #360 for details.
- RoHS Compliant.
- For more information please go to: www.lutron.com/HilumeLED

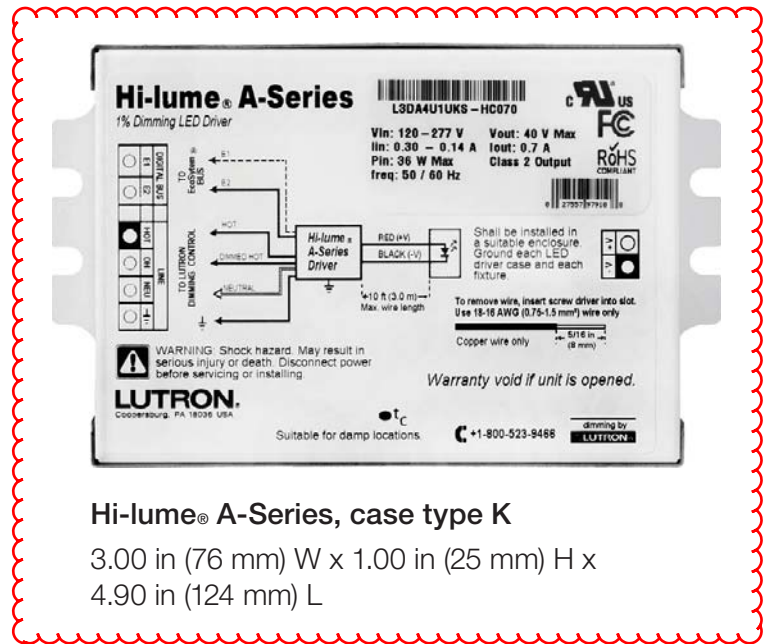

Hi-lume® A-Series, case type K

3.00 in (76 mm) W x 1.00 in (25 mm) H x
4.90 in (124 mm) L



Hi-lume® A-Series, case type M

1.18 in (30 mm) W x 1.00 in (25 mm) H x
14.25 in (362 mm) L

Job Name:	Model Numbers:	
<input type="text"/>	<input type="text"/>	<input type="text"/>
Job Number:	<input type="text"/>	<input type="text"/>

Specifications

Performance

- Dimming Range: 100% to 1%
- Operating Voltage: 120–277 V \sim at 50/60 Hz
- A rated lifetime of 50,000 hours @ $t_c = 65^\circ\text{C}$. Contact Lutron for derating information.
- Patented thermal foldback protection.
- LEDs turn on to any dimmed level without going to full brightness.
- Non-volatile memory restores all driver settings after power failure.
- Power Factor: > 0.90 for loads greater than 25 W
- Standby Power Consumption: < 1.0 W
- Total Harmonic Distortion (THD): < 20% for loads greater than 25 W
- Inrush Current: < 2 A
- Inrush Current Limiting Circuitry: eliminates circuit breaker tripping, switch arcing and relay failure.
- Open circuit protected
- Short circuit protected
- Turn-on time: ≤ 1 second
- PWM Dimming Frequency: 550 Hz

Environmental

- Sound Rating: Class A.
- Relative Humidity: Maximum 90% non-condensing.
- Minimum operating ambient temperature $t_a = 32^\circ\text{F}$ (0°C).

Standards

- Meets ANSI C62.41 category A surge protection standards up to and including 4 kV.
- FCC Part 15 compliant for commercial applications at 120 V \sim or 277 V \sim .
- Manufacturing facilities employ ESD reduction practices that comply with the requirements of ANSI/ESD S20.20.

- Lutron® Quality Systems registered to ISO 9001.2008.
- UL 8750 recognized.
- Class 2 output available.
- Models available to meet LED Driver requirements for Energy Star 1.1.

Driver Wiring & Mounting

- Driver is grounded by a mounting screw to the grounded fixture (or by terminal connection on the K case).
- Terminal blocks on the driver accept one solid wire per terminal from 18 to 16 AWG (0.75 to 1.5 mm²).
- Fixture must be grounded in accordance with local and national electrical codes.

- Maximum driver-to-LED light engine wire length for **Constant-Current Drivers:**

Wire Gauge	Maximum Lead Length		
	200 mA to 700 mA	710 mA to 1.50 A	1.51 A to 2.10 A
18 AWG (0.75 mm ²)	30 ft (9 m)	15 ft (4.5 m)	10 ft (3 m)
16 AWG (1.5 mm ²)	35 ft (10.5 m)	25 ft (7.5 m)	15 ft (4.5 m)
14 AWG (2.5 mm ²)	50 ft (15 m)	40 ft (12 m)	25 ft (7.5 m)
12 AWG (4.0 mm ²)	100 ft (30 m)	60 ft (18 m)	40 ft (12 m)

- Maximum driver-to-LED light engine wire length for **Constant-Voltage Drivers:**

Wire Gauge	Maximum Lead Length		
	10 V to 20 V	20.5 V to 40 V	40.5 V to 60 V
18 AWG (0.75 mm ²)	10 ft (3 m)	15 ft (4.5 m)	30 ft (9 m)
16 AWG (1.5 mm ²)	15 ft (4.5 m)	25 ft (7.5 m)	50 ft (15 m)
14 AWG (2.5 mm ²)	25 ft (7.5 m)	40 ft (12 m)	75 ft (22.5 m)
12 AWG (4.0 mm ²)	40 ft (12 m)	60 ft (18 m)	100 ft (30 m)

Job Name: <input style="width: 90%;" type="text"/>	Model Numbers: <input style="width: 95%;" type="text"/>
Job Number: <input style="width: 80%;" type="text"/>	<input style="width: 95%;" type="text"/>

How to Build a Model Number: Hi-lume® A-Series

→ **L3DA4U1U**

Case Size:

→ K = Compact
M = Stick

Case Style:

S = Studded (K case only)
→ N = Non-Studded

example: L3DA4U1UKS-HC070

For further assistance selecting your model number, contact our LED Center of Excellence at 1.877.346.5338 or LEDs@lutron.com

Current Level (for Constant-Current):

020 = 0.20 A; 021 = 0.21 A . . . 070 = 0.70 A . . . 210 = 2.10 A

Voltage Level (for Constant-Voltage):

100 = 10.0 V; 105 = 10.5 V . . . 600 = 60.0 V

← **240=24.0V**

Driver Output:

- C = Constant-current driver with pulse width modulation (PWM) dimming
- A = Constant-current driver with constant-current reduction (CCR) dimming
- V = Constant-voltage driver with pulse width modulation (PWM) dimming

LED Load Output Range (see the following pages for more detail):

Class 2 Constant-Voltage

- A = 10.0 V–12.0 V
- B = 12.5 V–20.0 V
- C = 20.5 V–24.0 V
- D = 24.5 V–38.0 V

Isolated Non-Class 2 Constant-Voltage

- X = 38.5 V–60.0 V

Class 2 Constant-Current

- E = 0.20 A–0.50 A 30 V–54 V
- F = 0.51 A–1.00 A 30 V–54 V
- G = 0.20 A–0.70 A 8 V–20 V
- H = 0.20 A–0.70 A 15 V–38 V
- I = 0.71 A–1.05 A 8 V–20 V
- J = 0.71 A–1.05 A 15 V–38 V
- K = 1.06 A–1.50 A 8 V–20 V
- L = 1.06 A–1.50 A 15 V–38 V
- M = 1.51 A–2.10 A 8 V–20 V

Isolated Non-Class 2 Constant-Current

- Y = 0.20 A–0.50 A 30 V–60 V
- Z = 0.51 A–1.00 A 30 V–60 V

Job Name: <input type="text"/>	Model Numbers: <input type="text"/>	
Job Number: <input type="text"/>	<input type="text"/>	<input type="text"/>

“C” Output Range, Voltage Driver Models

Driver Type	Output Dimming Method	Output Voltage	Output Current	Output Power	Standards Recognition
Constant-Voltage Driver (Class 2)	Pulse Width Modulation (PWM)	20.5–24.0 V PWM	1.95–0.21 A	5–40 W	

Voltage Driver Operation Range:

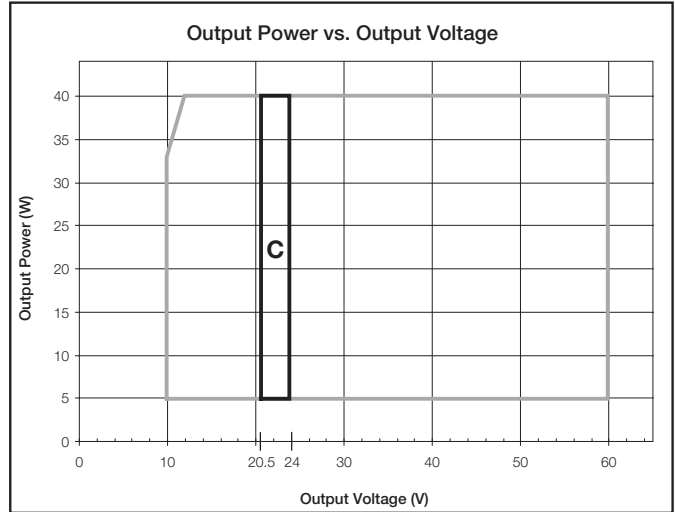
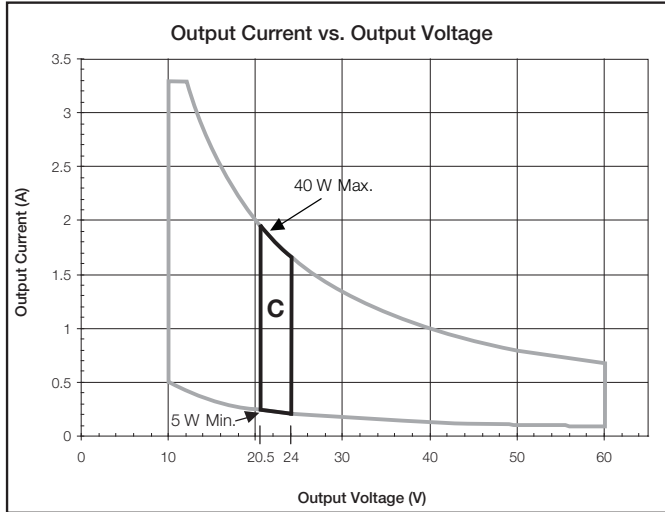

Typical Performance Specifications:

Parameter	120 V~	240 V~	277 V~	Test Conditions
Input Current	370 mA	190 mA	170 mA	t _a = 25 °C, 24.0 V 40 W load, Max. Light Output, K enclosure
Power Factor	0.99	0.97	0.96	
THD	10%	10%	12%	
Driver Efficiency	86%	87%	88%	

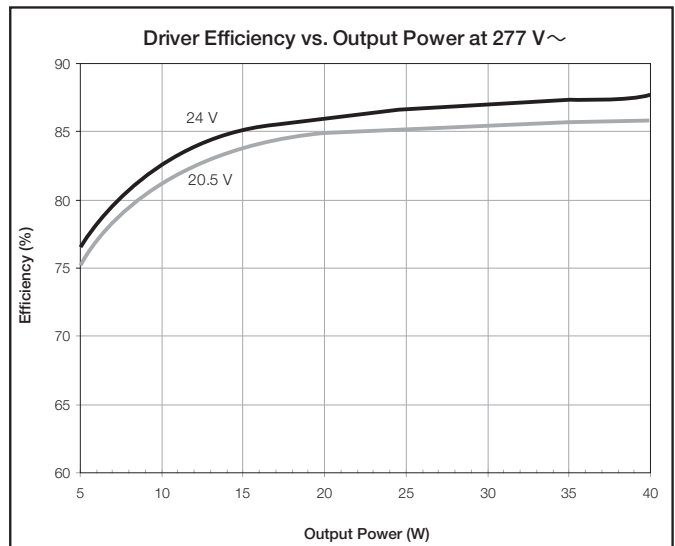
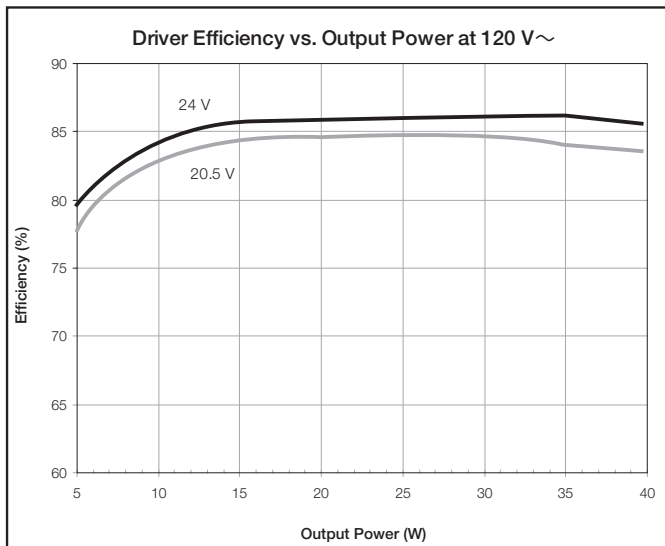

Job Name: <input style="width: 90%; height: 20px;" type="text"/>	Model Numbers: <input style="width: 90%; height: 20px;" type="text"/>	
Job Number: <input style="width: 90%; height: 20px;" type="text"/>		

K Case: Case Dimensions

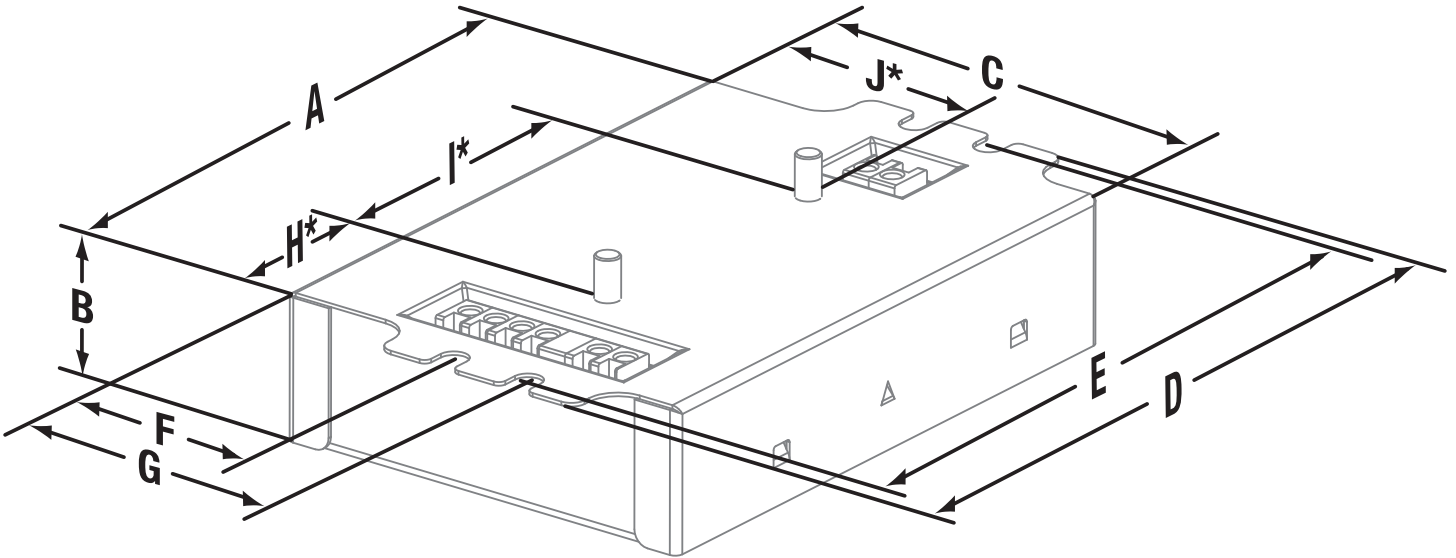

K Case: Connector Location Dimensions

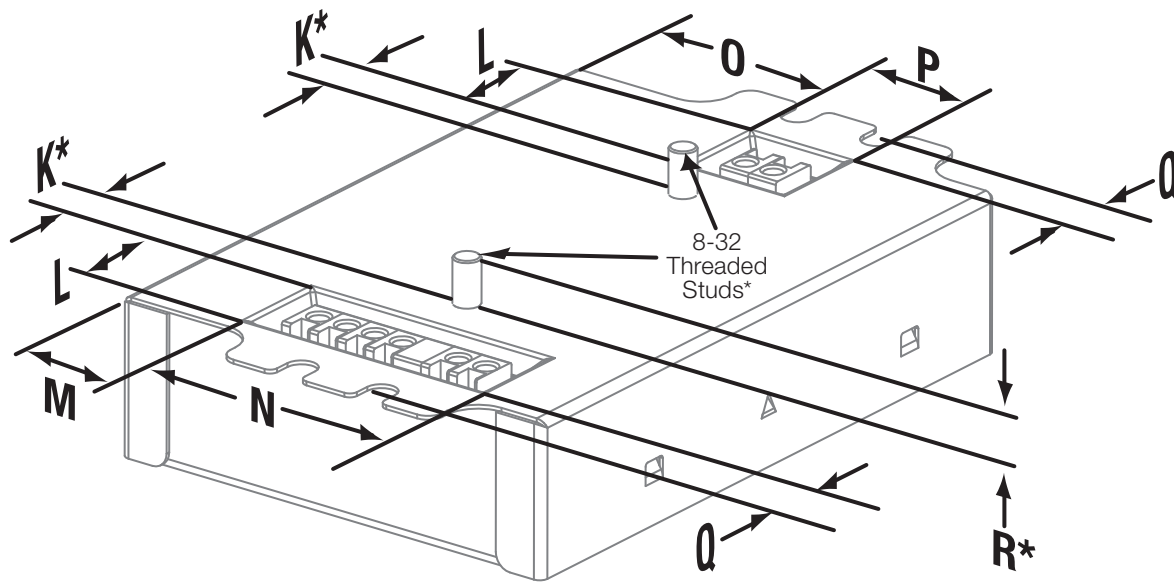

A	4.20 in (107 mm)	F	1.42 in (36 mm)	K*	0.33 in (8.3 mm)	P	0.74 in (19 mm)
B	1.00 in (25 mm)	G	1.99 in (51 mm)	L	0.65 in (16.5 mm)	Q	0.32 in (8 mm)
C	3.00 in (76 mm)	H*	1.11 in (28 mm)	M	0.75 in (19 mm)	R*	0.29 in (7 mm)
D	4.90 in (124 mm)	I*	2.00 in (51 mm)	N	1.73 in (44 mm)		
E	4.60 in (117 mm) (mounting center)	J*	1.60 in (41 mm)	O	1.33 in (34 mm)		

* Applies to studded K case only.

Job Name:	Model Numbers:	
<input type="text"/>	<input type="text"/>	<input type="text"/>
Job Number:	<input type="text"/>	<input type="text"/>

K Case: Side Entry Connector Location Dimensions (Non-Studded)

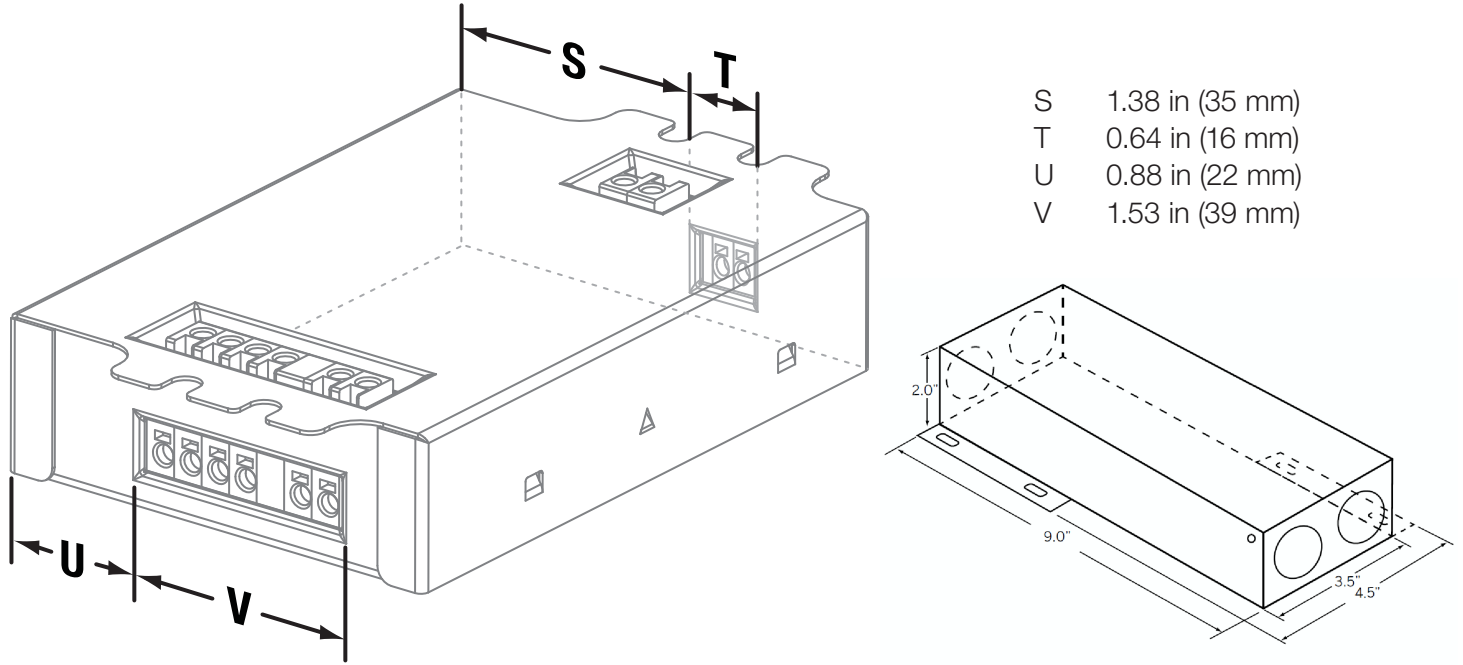

- S 1.38 in (35 mm)
- T 0.64 in (16 mm)
- U 0.88 in (22 mm)
- V 1.53 in (39 mm)

For remote mounting

Standard enclosure supplied with drivers shown above.

M Case: Case Dimensions

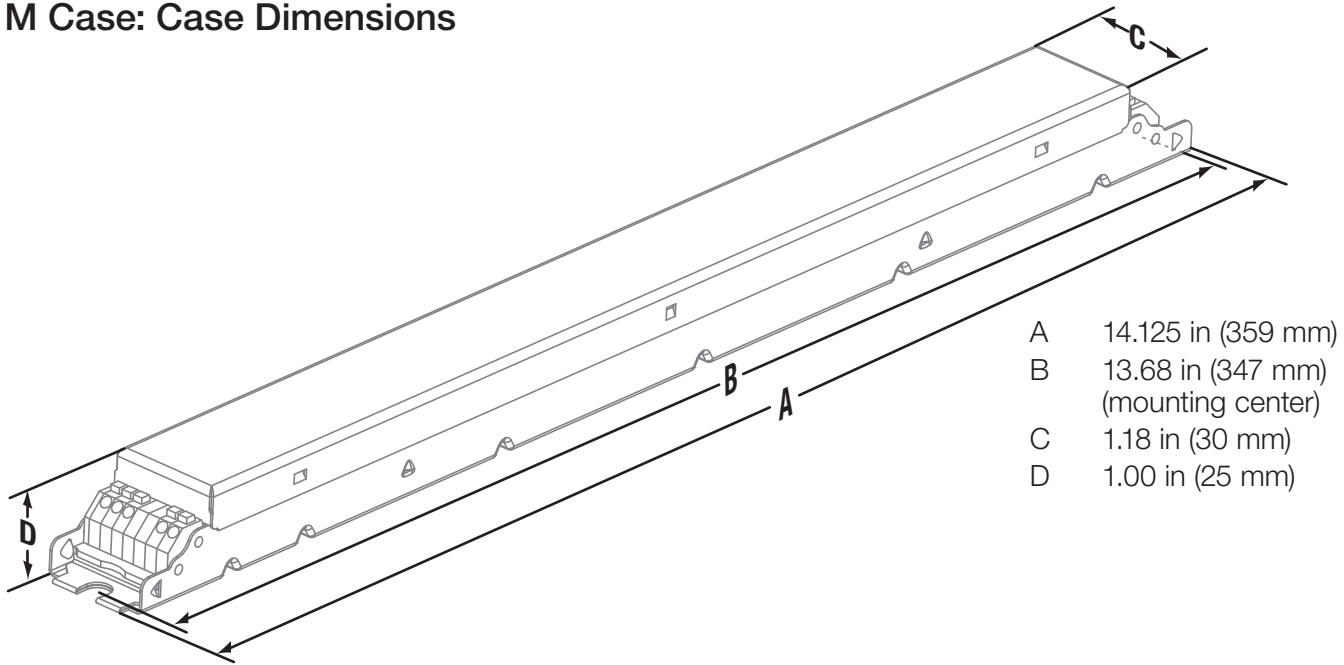

- A 14.125 in (359 mm)
- B 13.68 in (347 mm)
(mounting center)
- C 1.18 in (30 mm)
- D 1.00 in (25 mm)

Job Name:	Model Numbers:	
<input type="text"/>	<input type="text"/>	<input type="text"/>
Job Number:	<input type="text"/>	<input type="text"/>

Wiring Diagram for 3-Wire Control

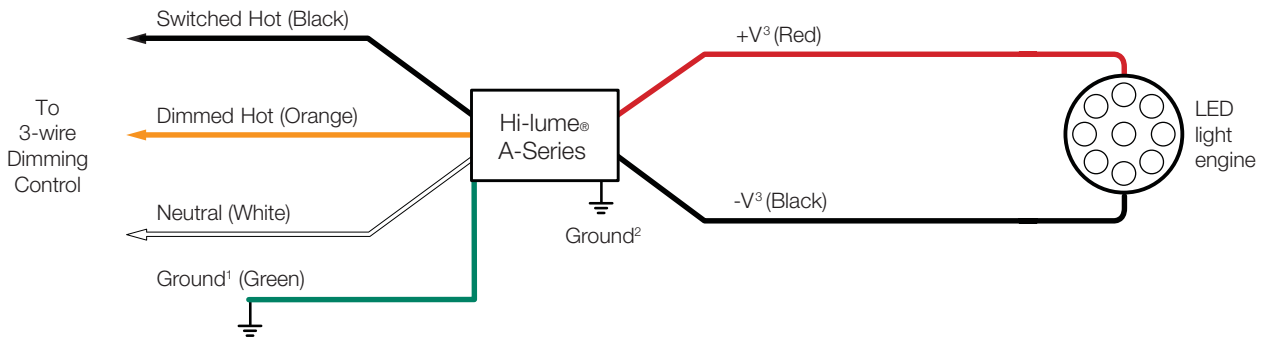

Wiring Diagram for EcoSystem® Digital Control

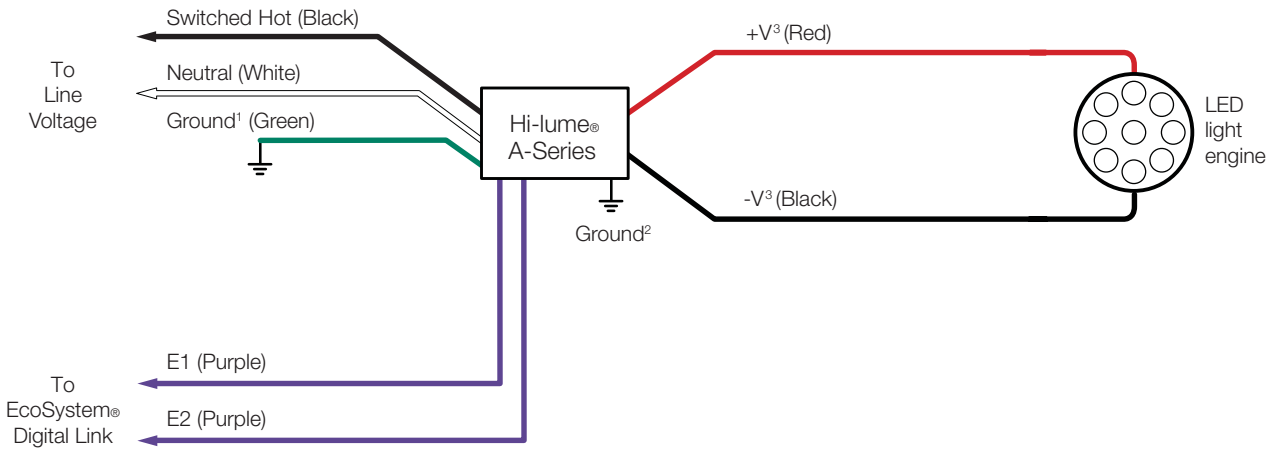

Note: Colors shown correspond to terminal blocks on driver.

- ¹ Ground wire connection available on K case models only.
- ² Fixture and driver case must be grounded in accordance with local and national electrical codes.
- ³ For maximum driver-to-LED light engine wire length, see charts in **Specifications—Driver Wiring & Mounting** section.

Job Name:	Model Numbers:	
<input type="text"/>	<input type="text"/>	<input type="text"/>
Job Number:	<input type="text"/>	<input type="text"/>

Compatible Controls

- Guaranteed performance specifications with the controls listed in the chart below.
- For assistance selecting controls, contact our LED Center of Excellence at 1.877.346.5338 or LEDs@lutron.com

Product	Part Number		Drivers per Control		Measured Light Output Range
	120 V~	277 V~	120 V~	277 V~	
3-wire Controls: Requires 3rd wire for control signal, see 3-wire diagram on previous page					
Nova T [☆] ®	NTF-10-	NTF-10-277-	1-41	1-44	100%-1%
	NTF-103P-	NTF-103P-277-	1-20	1-33	100%-1%
Nova®	NF-10-	NF-10-277-	1-41	1-44	100%-1%
	NF-103P-	NF-103P-277-	1-20	1-33	100%-1%
Vareo®	VF-10-		1-20	-	100%-1%
Skylark®	SF-10P-	SF-12P-277-	1-20	1-33	100%-1%
	SF-103P-	SF-12P-277-3	1-20	1-33	100%-1%
Diva®	DVF-103P-	DVF-103P-277-	1-20	1-33	100%-1%
	DVSCF-103P-	DVSCF-103P-277-	1-20	1-33	100%-1%
Ariadni®	AYF-103P-	AYF-103P-277-	1-20	1-44	100%-1%
Vierti®	VTF-6A-		1-15	1-33	100%-1%
Maestro®	MAF-6AM-	MAF-6AM-277-	1-15	1-20	100%-1%
	MSCF-6AM-	MSCF-6AM-277-	1-15	1-20	100%-1%
Maestro Wireless®	MRF2-F6AN-DV-		1-15	1-33	100%-1%
RadioTouch®	RTA-RX-F-		1-41	1-88	100%-1%
Spacer System®	SPSF-6A-	SPSF-6A-277-	1-15	1-20	100%-1%
	SPSF-6AM-	SPSF-6AM-277-	1-15	1-20	100%-1%
Lyneo® Lx	LXF-103PL-	LXF-103PL-277-	1-20	1-33	100%-1%
RadioRA® 2	RRD-F6AN-DV-		1-15	1-33	100%-1%
HomeWorks® QS	HQRD-F6AN-DV		1-15	1-33	100%-1%
Interfaces ¹	PHPM-3F-120		1-41	-	100%-1%
	PHPM-3F-DV		1-41	1-88	100%-1%
	GRX-FDBI-16A		1-41	1-88	100%-1%
GP Dimming Panels	Various		1-41	1-88	100%-1%
EcoSystem® Controls: See EcoSystem® Controls wiring diagram on previous page					
PowPak® dimming module with EcoSystem®	RMJ-ECO32-DV-B		32 per EcoSystem® link		100%-1%
Energi Savr Node™ with EcoSystem®	QSN-1ECO-S, QSN-2ECO-S		64 per EcoSystem® link		100%-1%
GRAFIK Eye® QS with EcoSystem®	QSGRJ-_E, QSGR-_E		64 per EcoSystem® link		100%-1%
Quantum®	Various		64 per EcoSystem® link		100%-1%

¹ For use with 3-wire controls or Commercial Systems, RadioRA® 2 Systems or Home Systems applications.

NOTE: Contact Lutron Technical Support for derating rules when using wallbox controls on the Hi-lume® A-Series LED Driver in multi-gang applications.

Job Name: <input type="text"/>	Model Numbers: <input type="text"/>	
Job Number: <input type="text"/>	<input type="text"/>	<input type="text"/>

EcoSystem® Wiring Diagrams

EcoSystem® Digital Link Overview

- The EcoSystem® Digital Link wiring (E1 and E2) connects the digital ballasts and drivers together to form a lighting control system.
- Each EcoSystem® Digital Link supports up to 64 digital ballasts, LED drivers or EcoSystem® Modules (e.g. C5-BMJ-16A, C5-XPJ-16A), 32 occupancy sensors (64 occupancy sensors with Energi Savr Node™ with EcoSystem®), 16 daylight sensors, and 64 wallstations or IR receivers.*
- Sensors do not directly connect to Hi-lume® A-Series LED drivers.
- E1 and E2 (EcoSystem® digital link wires) are polarity insensitive and can be wired in any topology.
- An Energi Savr Node™ unit with EcoSystem®, GRAFIK Eye® QS control unit with EcoSystem®, PowPak® dimming module with EcoSystem®, or Quantum® system provides power for the EcoSystem® Digital Link and supports system programming.*
- All EcoSystem® Digital Link programming is completed by using the Energi Savr app for *Apple iPad*, *iPod Touch* or *iPhone* mobile digital devices, GRAFIK Eye® QS with EcoSystem®, PowPak® dimming module with EcoSystem®, or Quantum® system.

EcoSystem® Digital Link Wiring

- Driver EcoSystem® Digital Link terminals only accept one 18 to 16 AWG (0.75 to 1.5 mm²) solid copper wire per terminal.
- Make sure that the supply breaker to the Digital Driver and EcoSystem® Digital Link Supply is OFF when wiring.
- Connect the two conductors to the two Digital Driver terminals E1 and E2 as shown.
- Using two different colors for E1 and E2 will reduce confusion when wiring several drivers together.
- The EcoSystem® Digital Link may be wired Class 1 or Class 2. Consult applicable electrical codes for proper wiring practices.

* PowPak® dimming module with EcoSystem® provides power for the EcoSystem® Digital Link and can support 32 digital ballasts, LED drivers or EcoSystem® Modules, 6 Wireless Occupancy Sensors, 1 Wireless Daylight Sensor, and 9 Pico® Wireless Controllers.

Apple, iPad, iPod Touch, and iPhone are trademarks of Apple Inc., registered in the U.S. and other countries.

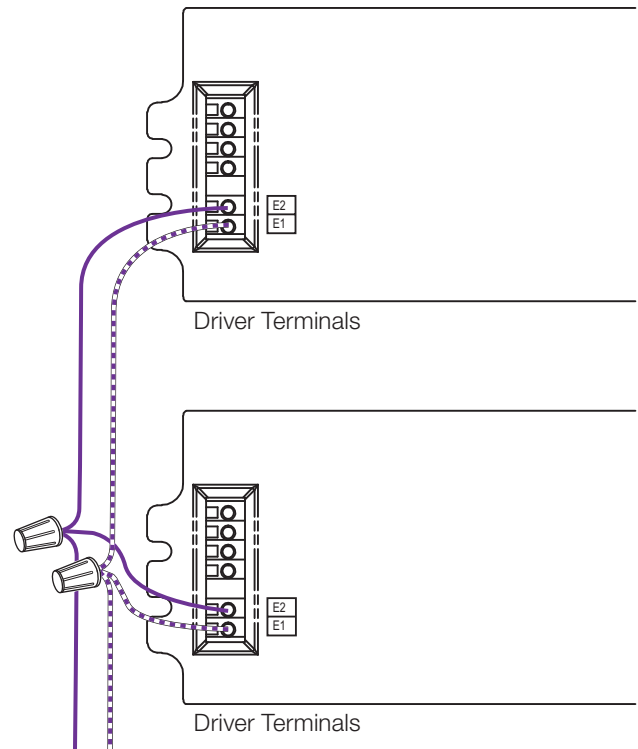

To the EcoSystem® Digital Bus and additional drivers and/or ballasts

Notes

- The EcoSystem® Digital Link Supply does not have to be located at the end of the Digital Link.
- EcoSystem® Digital Link length is limited by the wire gauge used for E1 and E2 as follows:

Wire Gauge	Digital Link Length (max)
12 AWG	2200 ft
14 AWG	1400 ft
16 AWG	900 ft
18 AWG	550 ft

Wire Size	Digital Link Length (max)
4.0 mm ²	828 m
2.5 mm ²	517 m
1.5 mm ²	310 m
1.0 mm ²	207 m
0.75 mm ²	155 m

Job Name:	Model Numbers:	
<input type="text"/>	<input type="text"/>	<input type="text"/>
Job Number:	<input type="text"/>	<input type="text"/>

ELECTRICIANS AND CONTRACTORS**Driver Leads**

Maximum driver-to-LED light engine wire length for

Constant-Current Drivers:

Wire Gauge	Maximum Lead Length		
	200 mA to 700 mA	710 mA to 1.50 A	1.51 A to 2.10 A
18 AWG (0.75 mm ²)	30 ft (9 m)	15 ft (4.5 m)	10 ft (3 m)
16 AWG (1.5 mm ²)	35 ft (10.5 m)	25 ft (7.5 m)	15 ft (4.5 m)
14 AWG (2.5 mm ²)	50 ft (15 m)	40 ft (12 m)	25 ft (7.5 m)
12 AWG (4.0 mm ²)	100 ft (30 m)	60 ft (18 m)	40 ft (12 m)

Maximum driver-to-LED light engine wire length for

Constant-Voltage Drivers:

Wire Gauge	Maximum Lead Length		
	10 V to 20 V	20.5 V to 40 V	40.5 V to 60 V
18 AWG (0.75 mm ²)	10 ft (3 m)	15 ft (4.5 m)	30 ft (9 m)
16 AWG (1.5 mm ²)	15 ft (4.5 m)	25 ft (7.5 m)	50 ft (15 m)
14 AWG (2.5 mm ²)	25 ft (7.5 m)	40 ft (12 m)	75 ft (22.5 m)
12 AWG (4.0 mm ²)	40 ft (12 m)	60 ft (18 m)	100 ft (30 m)

Wiring and Grounding

Driver and lighting fixture must be grounded.
Drivers must be installed per national and local electrical codes.

LED Load Replacement

For Class 2 rated drivers, the LED load can be changed while the driver is installed and powered.

Maximum Driver Operating Temperature

Driver case temperature (t_c) must not exceed UL conditions of acceptability in end product.

For 50,000 hour lifetime, driver case temperature (t_c) must not exceed 65 °C.

FACILITIES MANAGERS**SERVICE****Warranty**

For warranty information, please visit <http://www.lutron.com/TechnicalDocumentLibrary/Ballast%20and%20Driver%20Warranty.pdf>

Replacement Parts

When ordering Lutron® replacement parts please provide the full model number. Consult Lutron if you have any questions.

Further Information

For further information, please visit us at www.lutron.com/hilumeLED or contact our LED Control Center of Excellence at 1.877.346.5338 or LEDs@lutron.com

Job Name:	Model Numbers:	
<input type="text"/>	<input type="text"/>	<input type="text"/>
Job Number:	<input type="text"/>	<input type="text"/>

Interlux Junction Box Installation Instructions

1. Turn Off Power
2. Provide 4" clearance on the short sides (ends) of junction box and 1" clearance on the long side.
3. Mount junction box base vertically with line voltage end of driver down and load side up.
4. Secure junction box base to building structure with #8 screws (by others)
5. Junction box base supplied with 2 x ½" knock outs each end.
6. Provide conduit connectors and conduit as required for supply wires.
7. Make up line voltage wire splices inside junction box.
8. Ground junction box with ground wire supplied.
9. Provide Class 2, plenum rated wire from driver to fixture and make up wire splices inside junction box.

Caution:

Never wire a LED fixture with live conductors. This will permanently damage the LED. Refer to wiring diagram supplied with junction box to confirm negative and positive connections.

10. Attach junction box cover with 2 x #8 screws supplied.
11. Ensure that the wiring from the fixture to the driver before turning on the power.