



RUBBER 3D and RUBBER 3D RGBW



WARNING:

INSTALL PRODUCT IN ACCORDANCE WITH LOCAL AND NATIONAL ELECTRICAL CODES BY A QUALIFIED ELECTRICIAN



WARNING:

FAILURE TO COMPLY WITH THE INSTALLATION INSTRUCTIONS MAY RESULT IN DEATH OR SEVERE INJURY.



WARNING:

READ ALL SAFETY INSTRUCTIONS INCLUDED WITH LUMINAIRE BEFORE INSTALLING LUMINAIRE. SAVE INSTRUCTIONS FOR FUTURE USE.

CAUTION:

THIS IS AN ELECTRONIC DEVICE. CARE MUST BE TAKEN DURING STORAGE AND HANDLING. STORE IN A CLEAN, COOL AND DRY LOCATION. ELECTROSTATIC DISCHARGE (ESD) CAN HARM THIS PRODUCT. AVOID STATIC DISCHARGE WHILE HANDLING THIS PRODUCT.

CAUTION:

INTER-LUX IS NOT RESPONSIBLE FOR THE STRUCTURAL INTEGRITY OF THE BUILDING TO SUPPORT THE LUMINAIRE. ADDITIONAL BACKING MAY BE REQUIRED.

LOCATE AND REVIEW ANY CONSTRUCTION PLANS AND INTER-LUX RECORD DRAWINGS FOR ALL FIXTURE RUNS. IT IS RECOMMENDED TO LOCARE AND LAY OUT ALL COMPONENTS FOR EACH FIXTURE "RUN". A FIXTURE RUN TYPICALLY CONSISTS OF JOINERS, LENGTHS OF HOUSING, AND ENDCAPS. BE SURE TO IDENTIFY ALL CORRECT LENGTHS FOR EACH FIXTURE RUN.

Rubber 3D

- RUB-WH-3D-39-3-CV-22-GE (E00126WH-A-DI)*
- RUB-WH-3D-39-3-CV-27-GE (E00126WH-M-DI)*
- RUB-WH-3D-39-3-CV-30-GE (E00126WH-W-DI)*
- RUB-WH-3D-39-3-CV-35-GE (E00126WH-T-DI)*
- RUB-WH-3D-39-3-CV-40-GE (E00126WH-N-DI)*
- RUB-WH-3D-197-3-CV-22-GE (E00127WH-A-DI)*
- RUB-WH-3D-197-3-CV-27-GE (E00127WH-M-DI)*
- RUB-WH-3D-197-3-CV-30-GE (E00127WH-W-DI)*
- RUB-WH-3D-197-3-CV-35-GE (E00127WH-T-DI)*
- RUB-WH-3D-197-3-CV-40-GE (E00127WH-N-DI)*
- RUB-CON-3D-39-3-CV-30-GE (E00126CC-W-DI)*
- RUB-CON-3D-197-3-CV-30-GE (E00126CC-W-DI)*

Rubber 3D RGBW

- RUB-WH-3D-39-5-CVDMX-R3-GE (E00126WH-V-DI)*
- RUB-WH-3D-197-5-CVDMX-R3-GE (E00127WH-V-DI)*

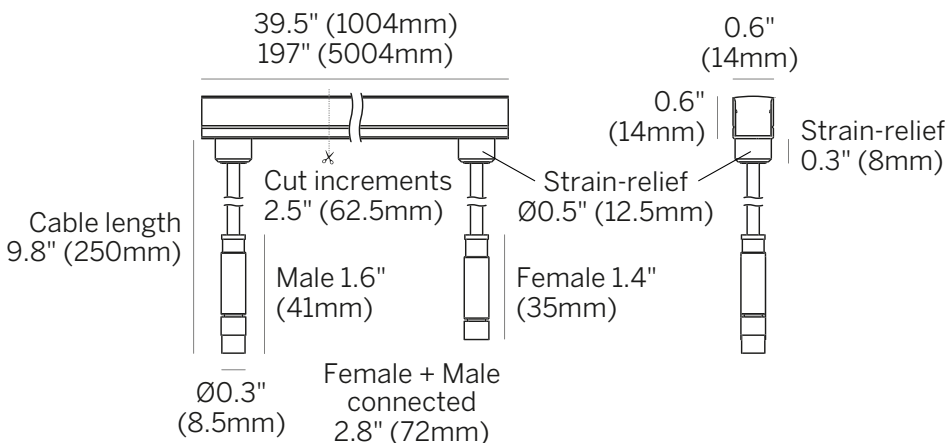

INSTALLATION
 INSTRUCTIONS
 VIDEO

1

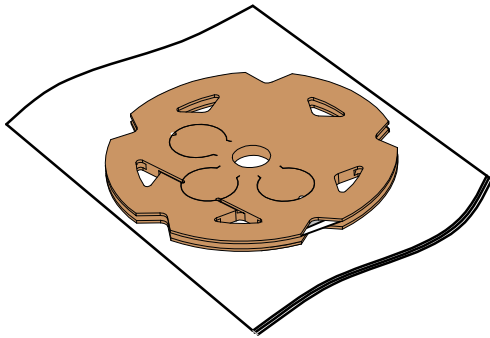

2

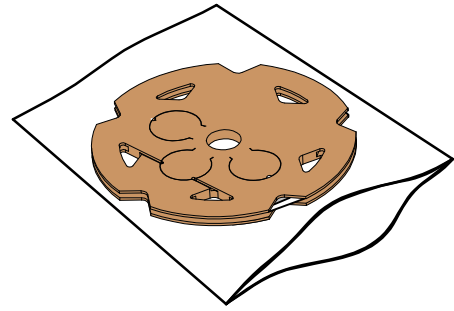

3

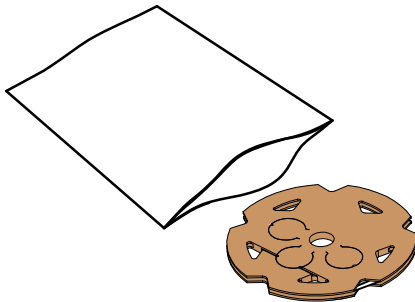

4



Please wear the provided gloves

5

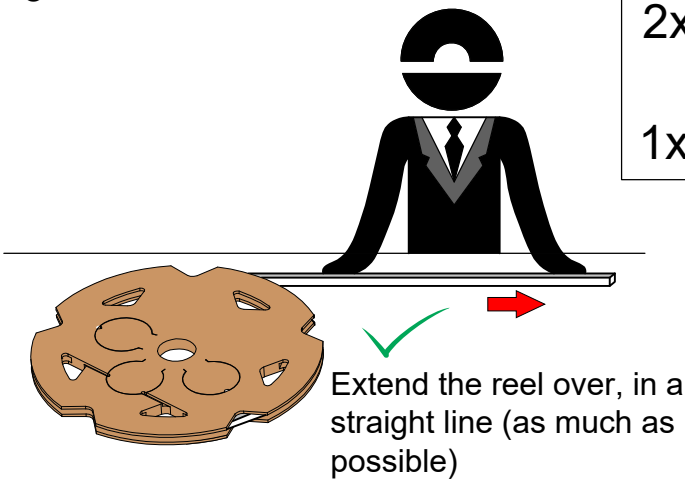
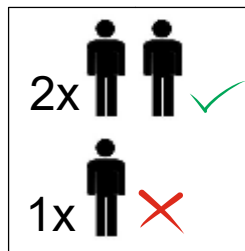

Extend the reel over, in a straight line (as much as possible)

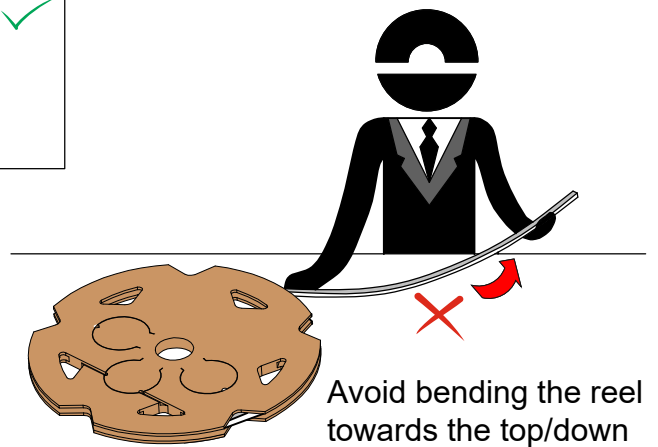

Avoid bending the reel towards the top/down

6

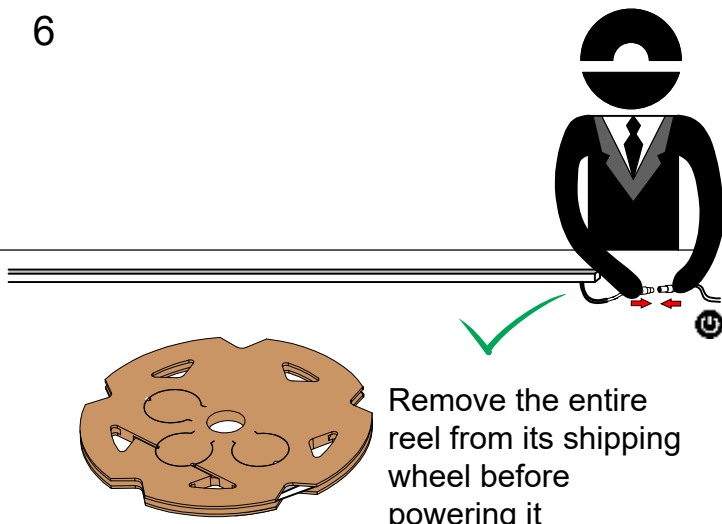

Remove the entire reel from its shipping wheel before powering it

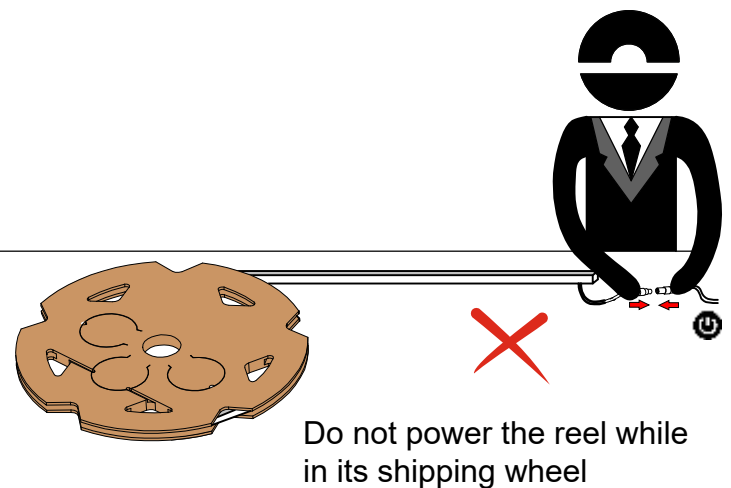

Do not power the reel while in its shipping wheel

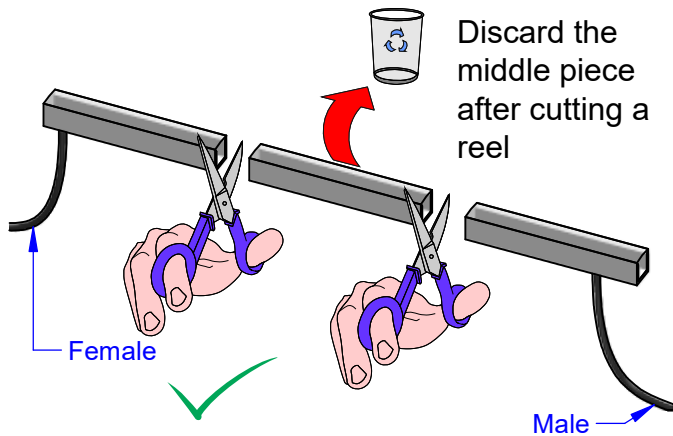
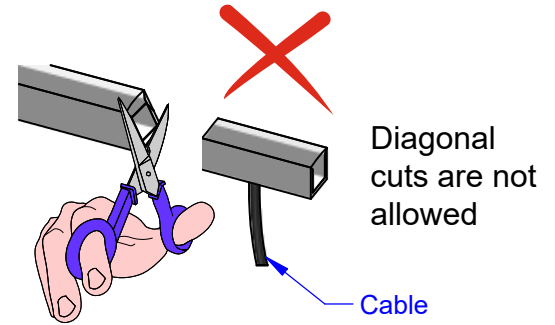
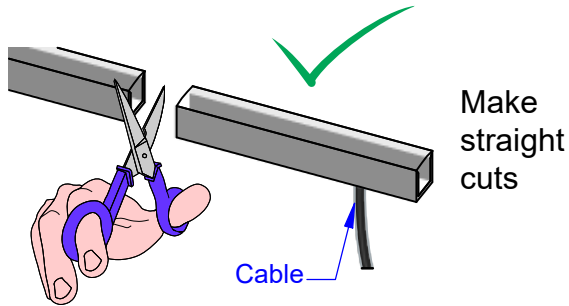

Minimum bending radius 9.9"

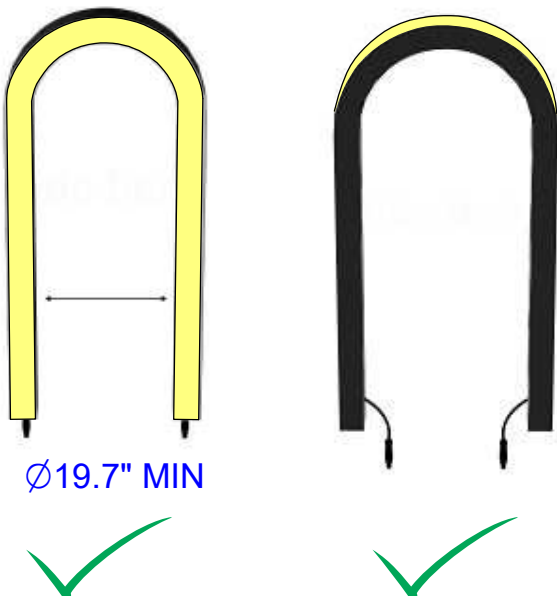

Do not bend the fixture in a radius tighter than 9.9"

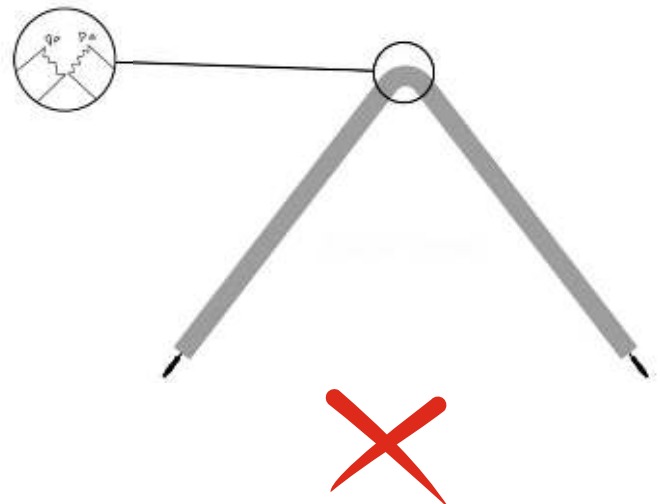



Do not twist the fixture at or close to the cable entry

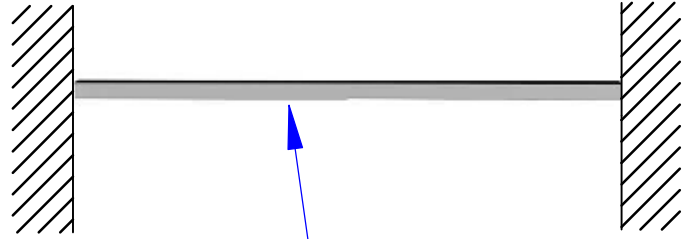

Do not suspend the fixture from its ends

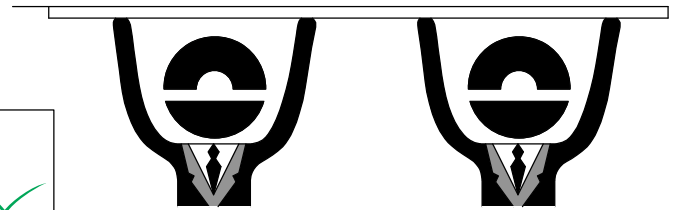
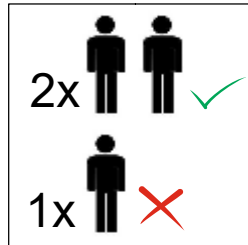
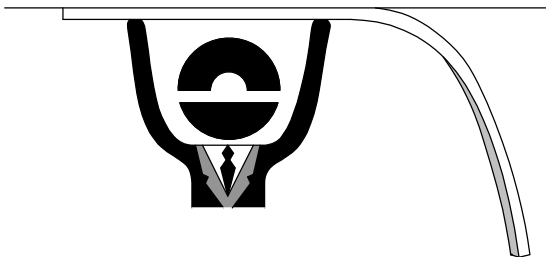

When installing it near water, allow for a minimum of 20" above water level

$X > 20"$

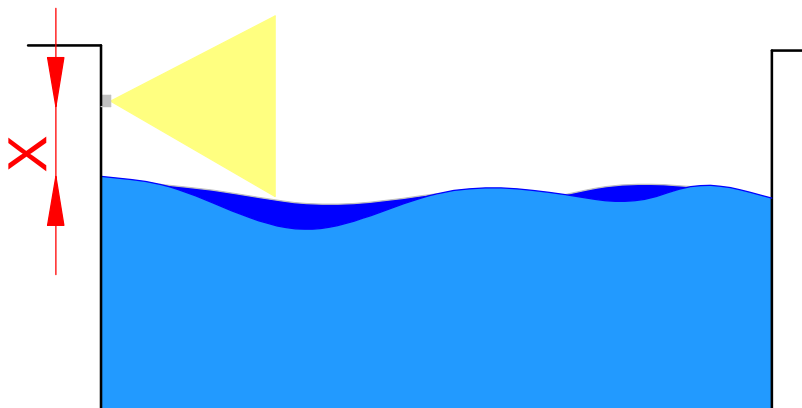

**WARNING!!!**

Read cutting instructions thoroughly before cutting the fixture.
You will end up with an unlit section of up to 2.46" if directions are not followed.

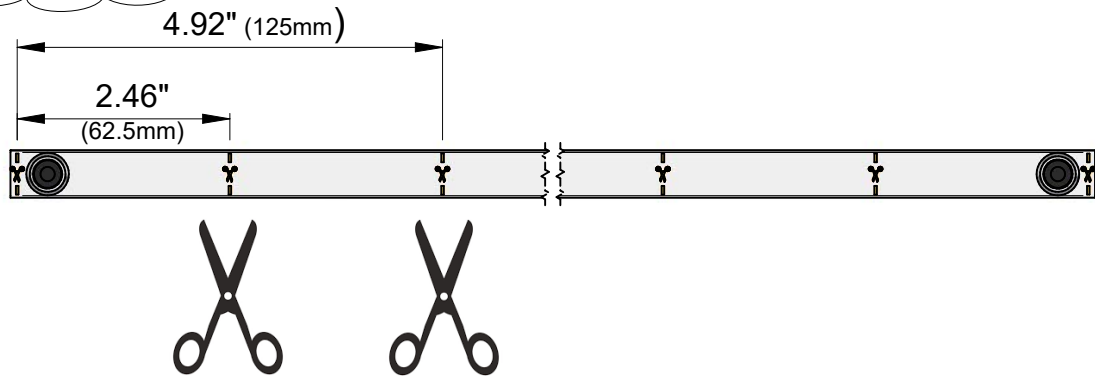

The strip has LED sections every 2.46" (62.5mm).
Cutting sections are marked at the bottom of the reel.

**1. MEASURING AND CUTTING INSTRUCTIONS:**

a) Add 2.46" (62.5mm) to the intended lit length, and mark the fixture at the bottom with a pen/marker, then do your first cut. b) Energize the fixture. After doing the first cut, you would end up with an unlit section of up to 2.46" (62.5mm), look at the back of the fixture and locate the last lit line, and make a second mark. c) De-energize the fixture, then make a third mark 0.25" towards the previously cut end, then do the second and final cut there. d) Energize and test again. e) Add the end cap as shown below.

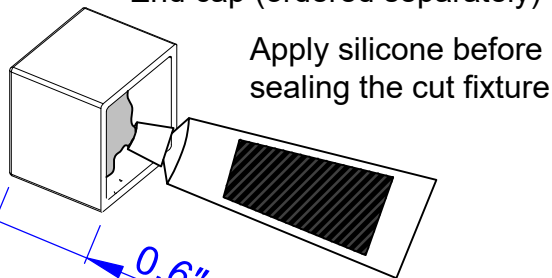
2 End cap (ordered separately)

Apply silicone before
sealing the cut fixture

**Warning!**

If using a mounting profile, the profile needs to be cut 0.6" shorter (the end cap will not fit in the profile)

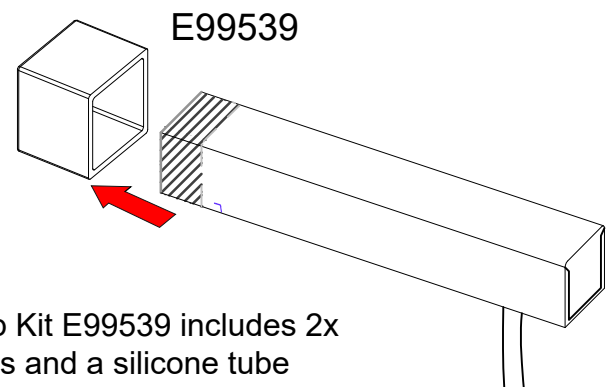
3

Cap Kit E99539 includes 2x
caps and a silicone tube

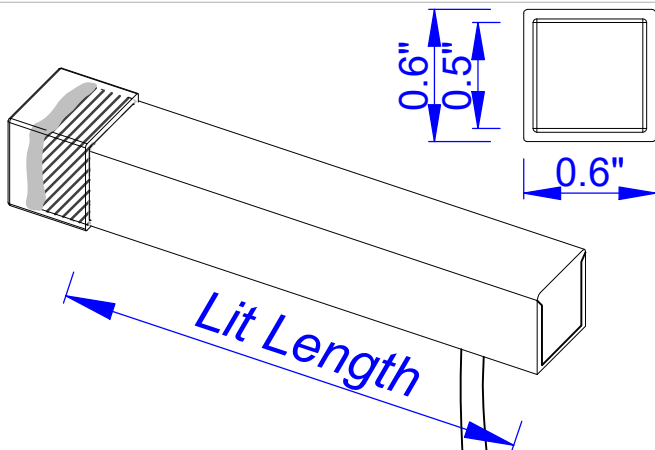
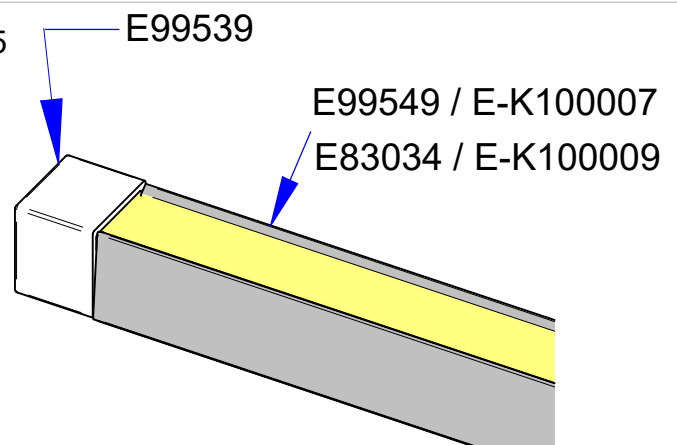
4**5**

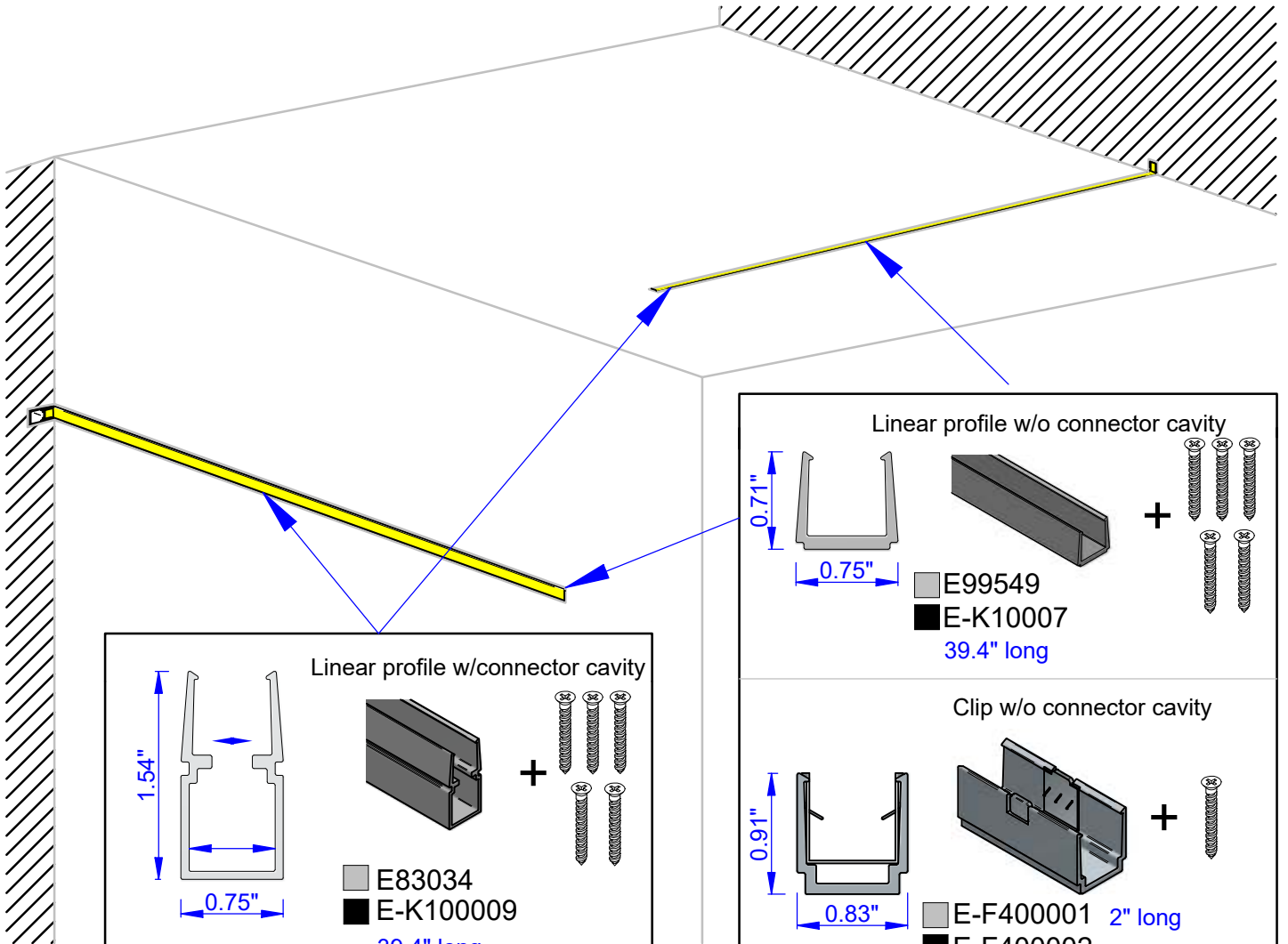
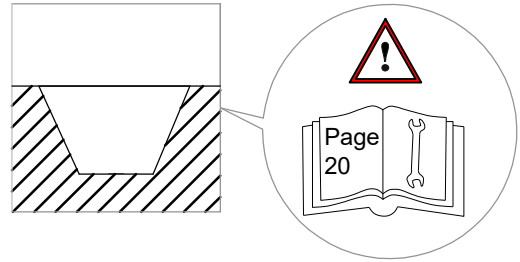
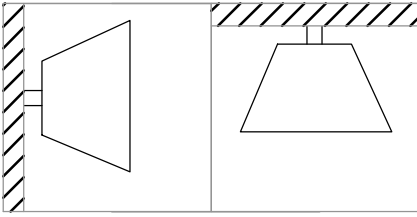

Linear profile w/connector cavity

■ E83034
 ■ E-K100009
 39.4" long

Clip w/connector cavity

■ E-F400003 2" long
 ■ E-F400004

Linear profile w/o connector cavity

■ E99549
 ■ E-K10007
 39.4" long

Clip w/o connector cavity

■ E-F400001 2" long
 ■ E-F400002

1

Linear profile with
connector cavity

■ E83034
■ E-K100009

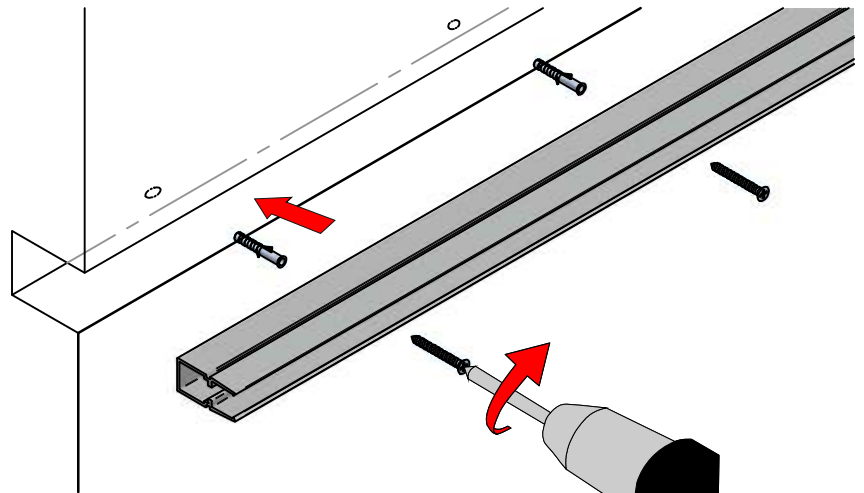
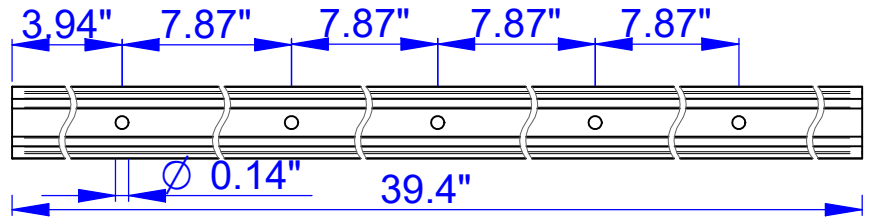
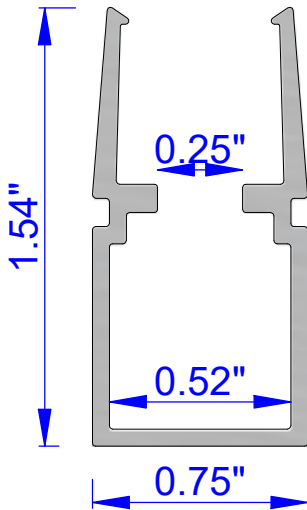

2

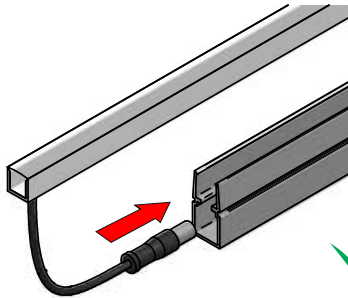
**Warning!**

- Cables and connectors must be inserted into the connector cavity of the linear profile before fixing it to the ground/wall. The connector won't fit through the top opening of the linear profile.
- The connector cavity at the bottom of the profile) only has room for one connection cross-section.
- On continuous runs, a dedicated feed-entry is required per driver, at the start of the first reel powered by each new driver.

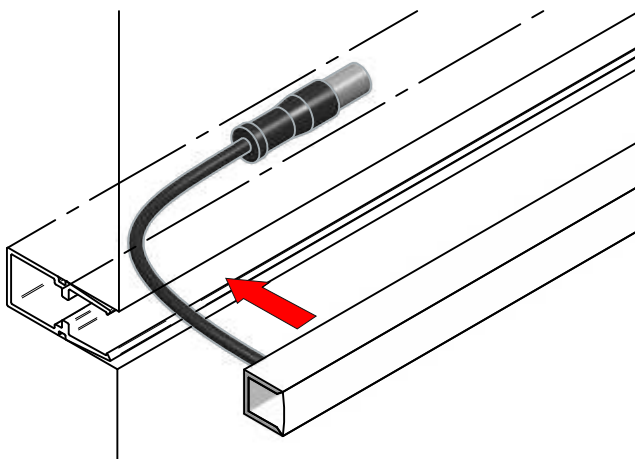

3

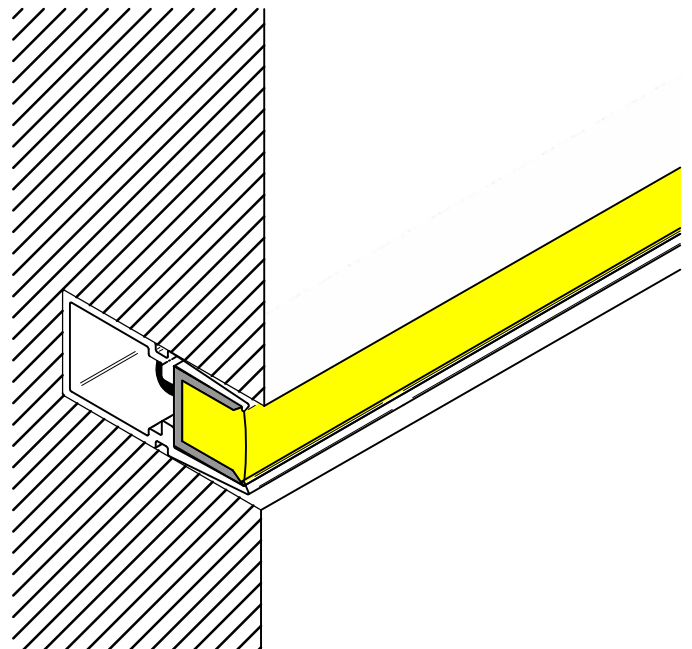

1 Linear profile
without connector cavity

- E99549
- E-K100007

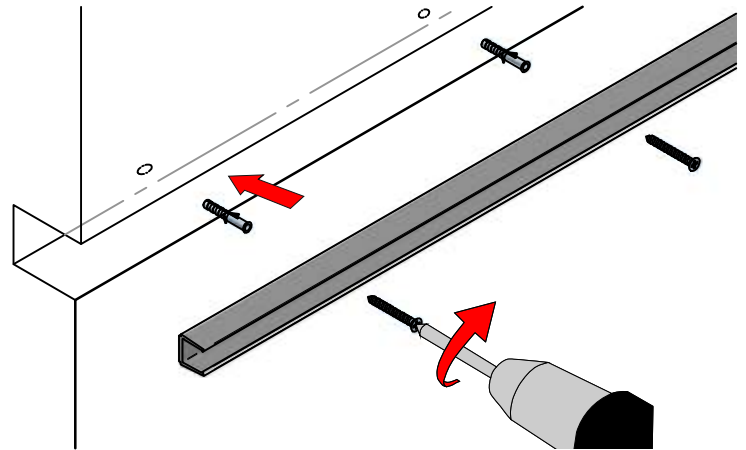
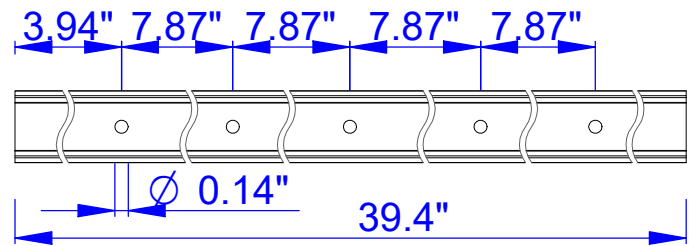
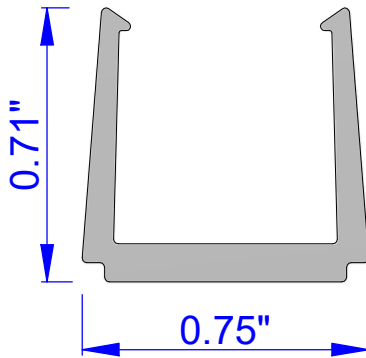

2

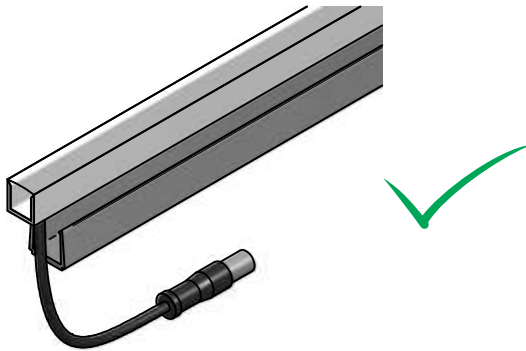
**Warning!**

- On continuous runs, a dedicated feed-entry is required per driver, at the start of the first reel powered by each new driver.

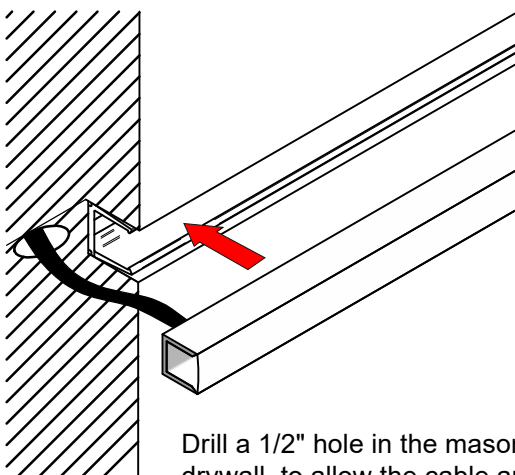

Drill a 1/2" hole in the masonry/
drywall, to allow the cable and
strain relief to go through.

3

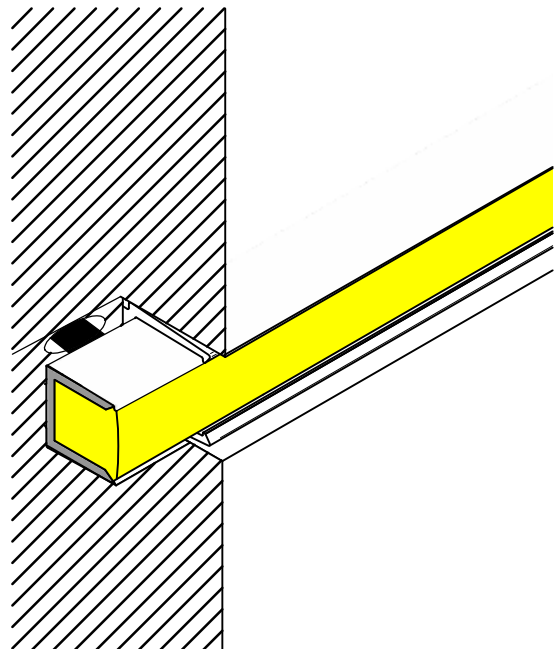

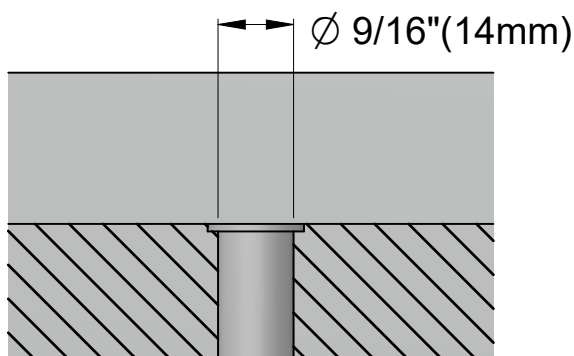
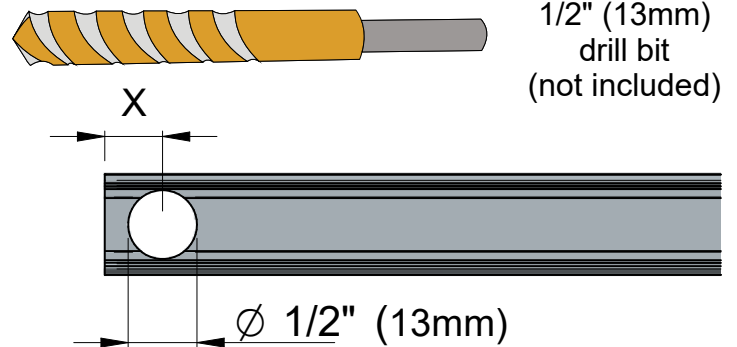
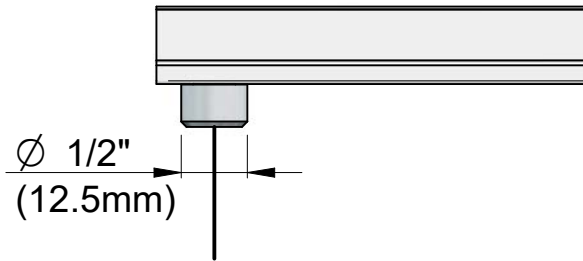
RUBBER 3D and RUBBER 3D RGBW

Align the Rubber reel cable, and mark the position in the linear profile, then drill a 1/2" hole.

A drilling template accessory (ordered separately) is offered to facilitate the process.

Drill a 9/16" hole in the masonry/drywall, to allow the cable and strain relief to go through.

Profile with connector cavity

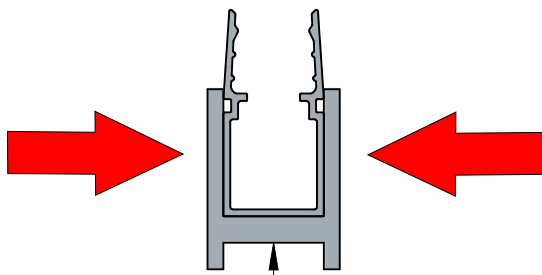

C-V200005 Drilling Template accessory

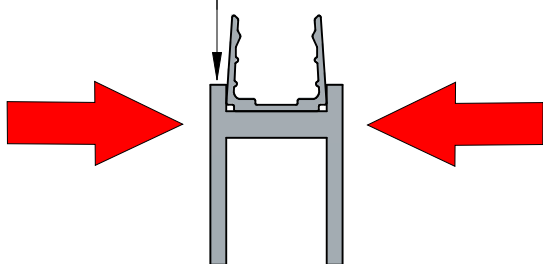
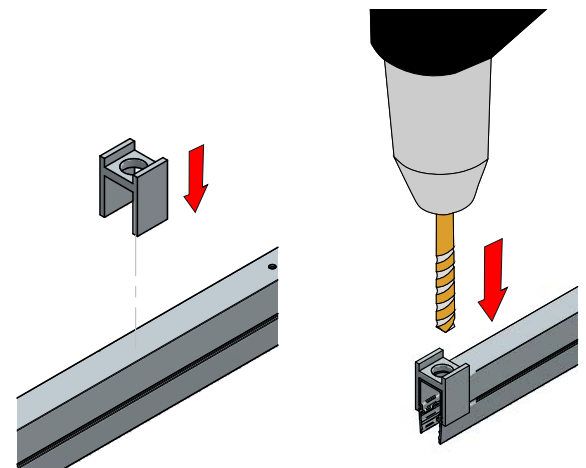

Profile without connector cavity

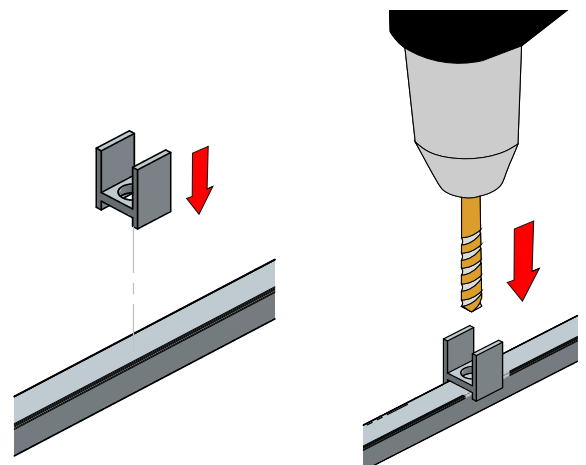

Clip w/o connector cavity

- E-F400001
- E-F400002

1.97" long

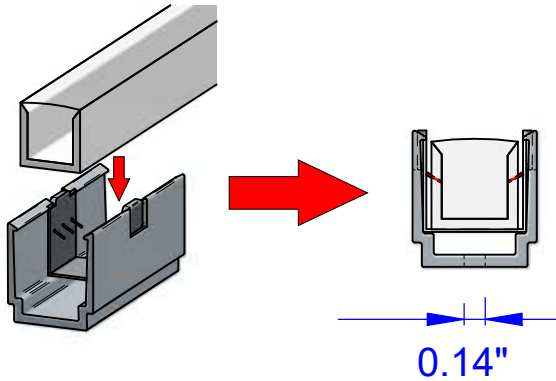
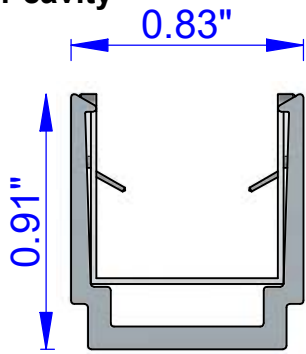

Suggested spacing between clips: 4" o.c.

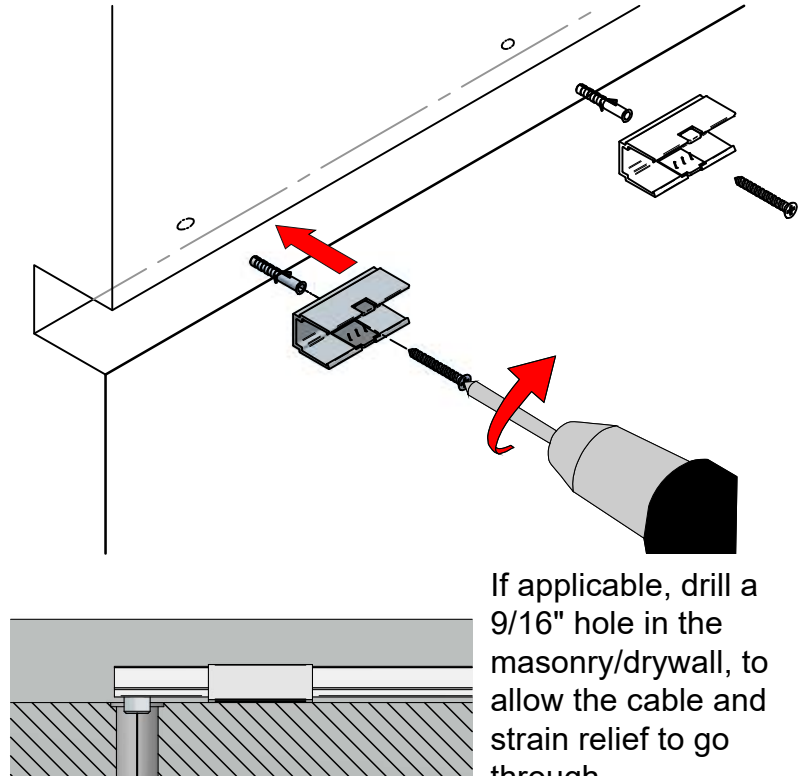

If applicable, drill a 9/16" hole in the masonry/drywall, to allow the cable and strain relief to go through.

Clip w/connector cavity

- E-F400003
- E-F400004

1.97" long

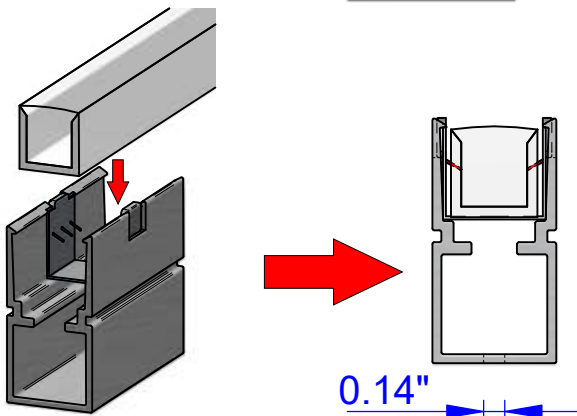
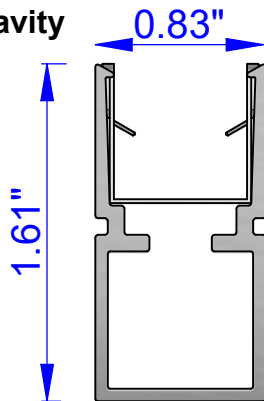

Suggested spacing between clips: 4" o.c.

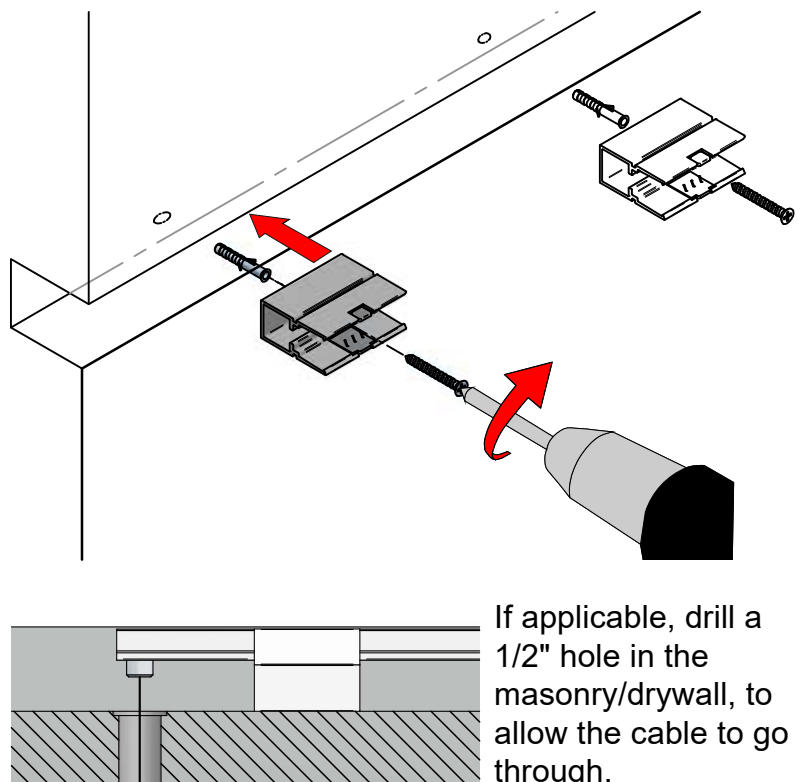

If applicable, drill a 1/2" hole in the masonry/drywall, to allow the cable to go through.

FIXTURE REMOVAL

- 1 SQUEEZE THE TAB IN THE MIDDLE OF THE CLIP

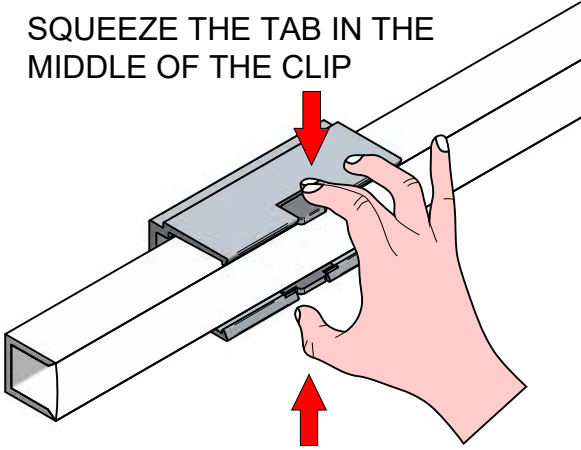

- 2 REMOVE THE FIXTURE

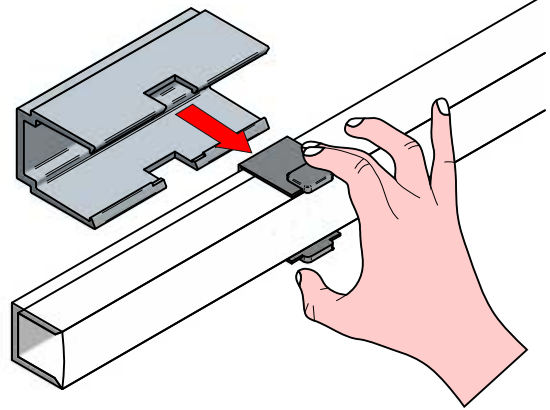

- 3 REPOSITION CLIP AND REINSTALL FIXTURE

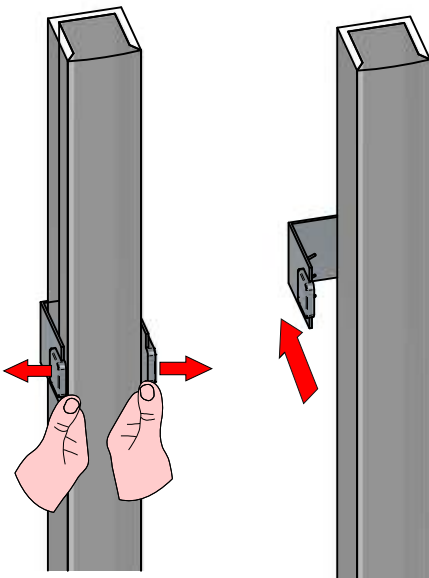

- 4

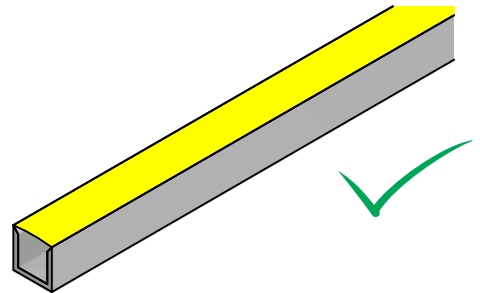

RUBBER 3D and RUBBER 3D RGBW

1

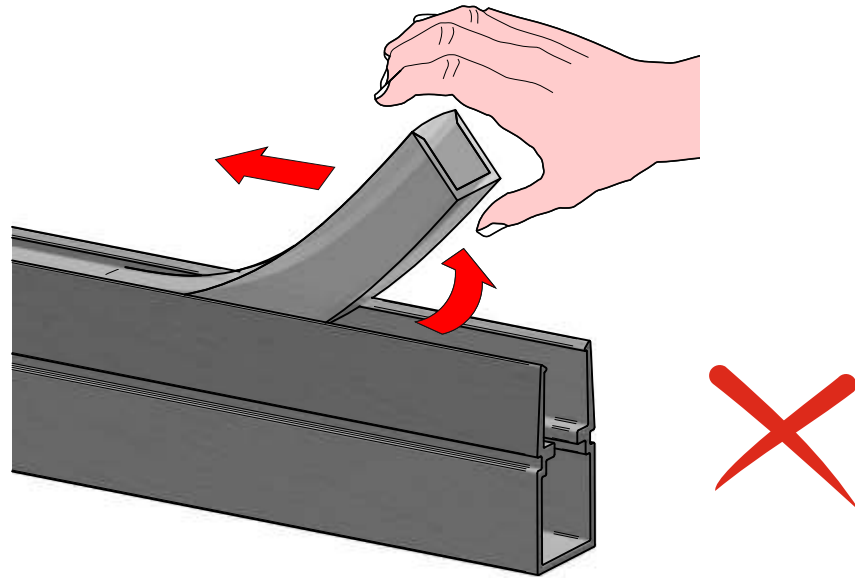

2

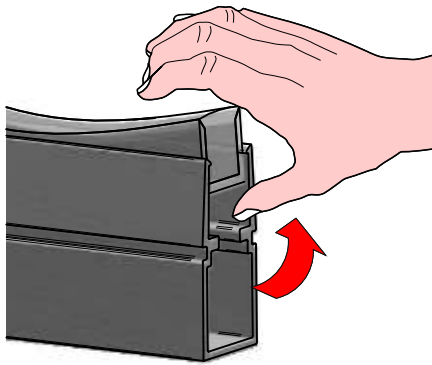

3

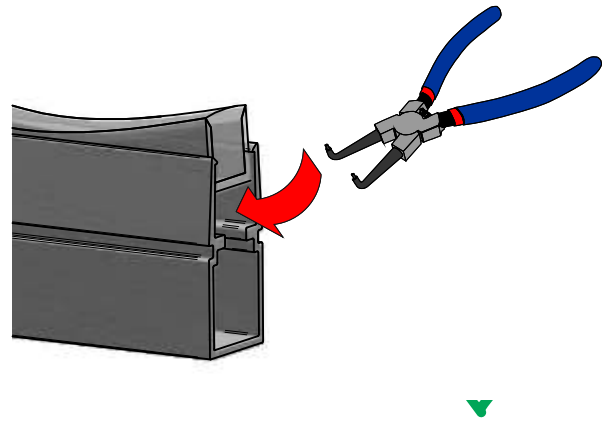

4

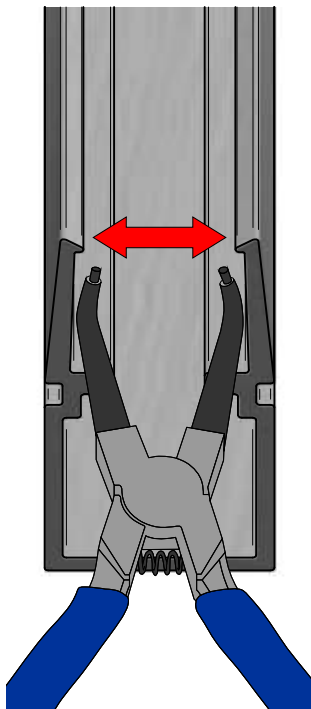

5

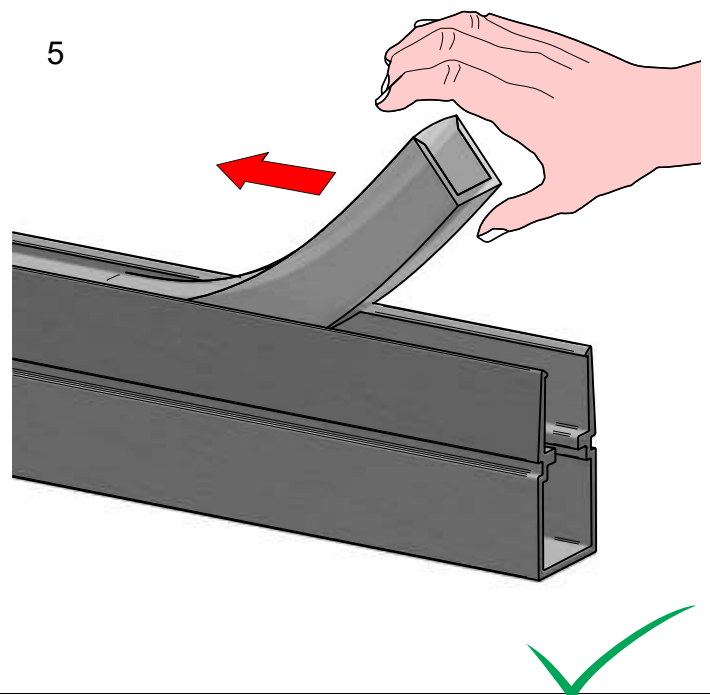

RUBBER 3D and RUBBER 3D RGBW

 E99541 Flexible profile

 E-K000011 Flexible Profile (*upcoming version)

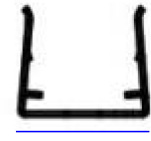

3/4" H (19mm H)

* 1/2" H (13mm H)

5/8" (16mm) W

39.7" L (1007mm L)

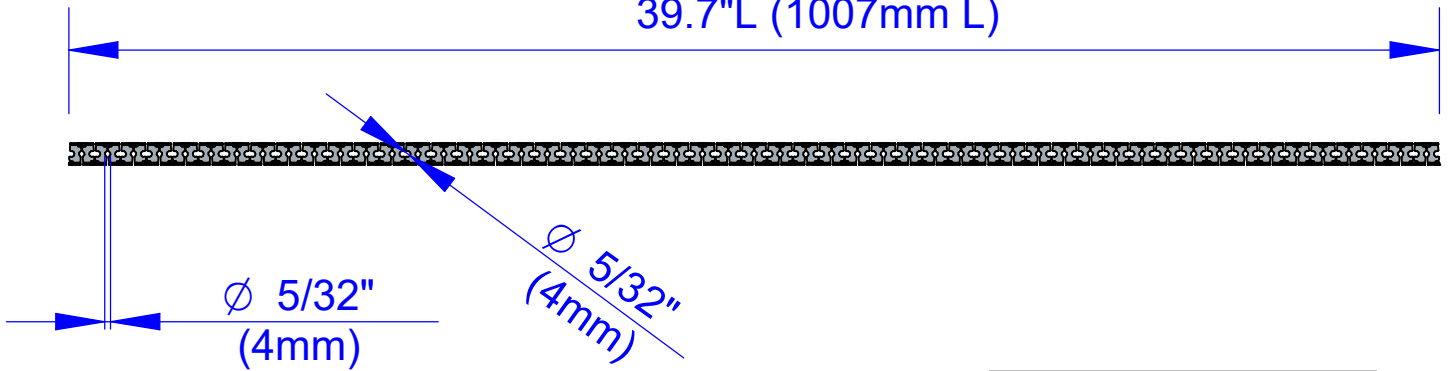

Screws and anchors
not included

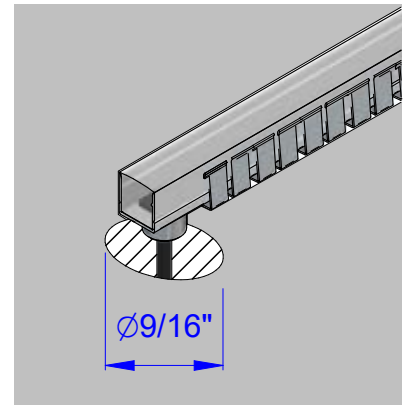

Drill a 9/16" hole in the masonry/drywall, to allow the cable and strain relief to go through.

Rubber reel
not included

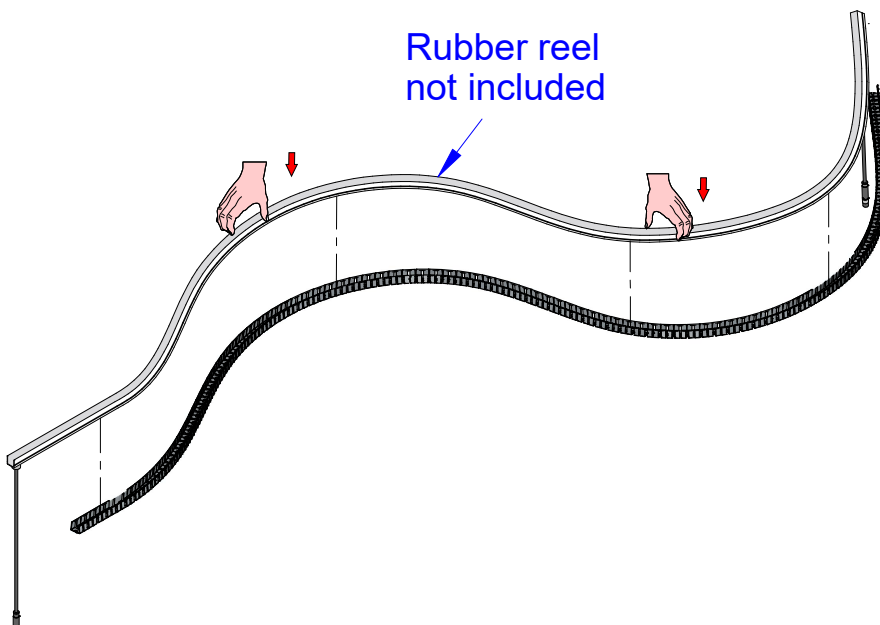

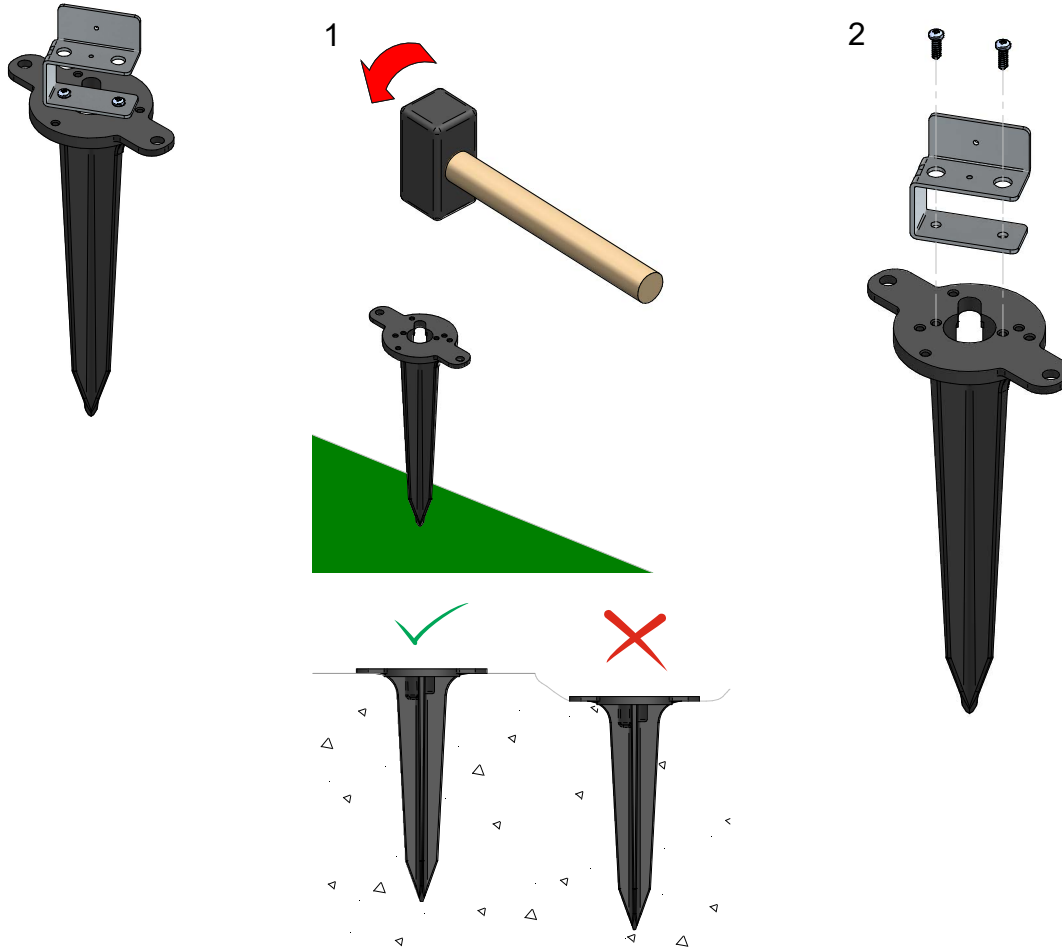
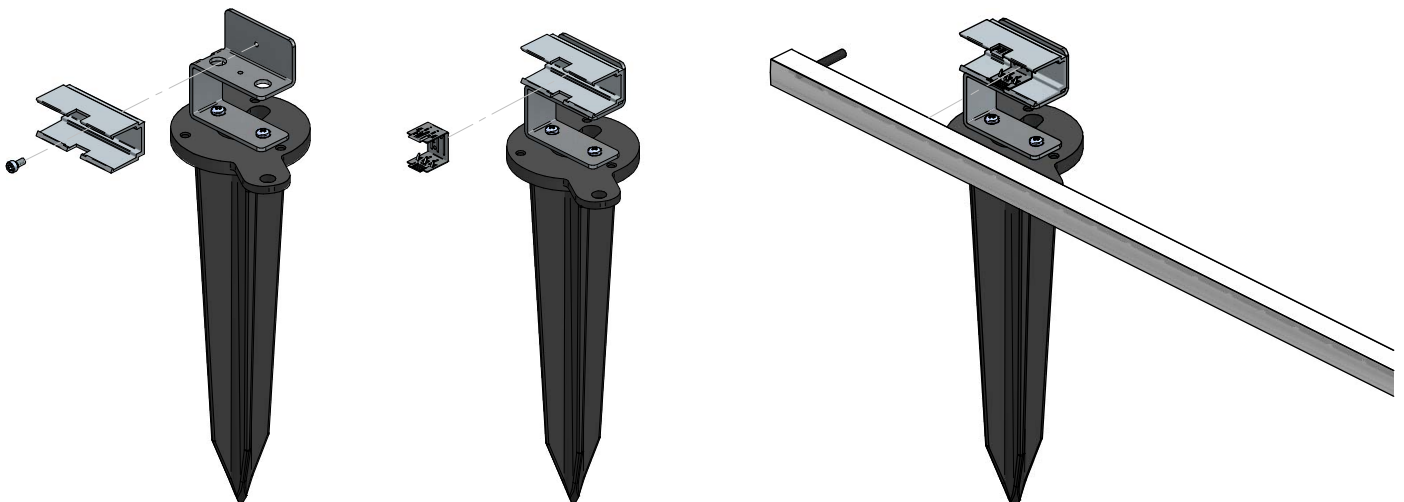
E83351 Spike with bracket (for soft ground installation)**Clip without connector cavity Installation**

Clip with connector cavity Installation

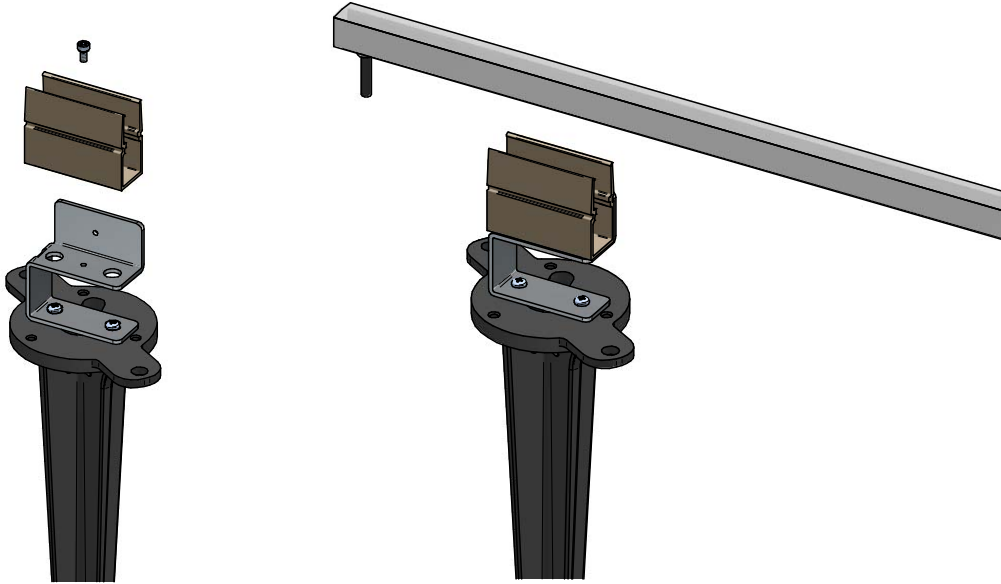

Linear profile with connector cavity Installation

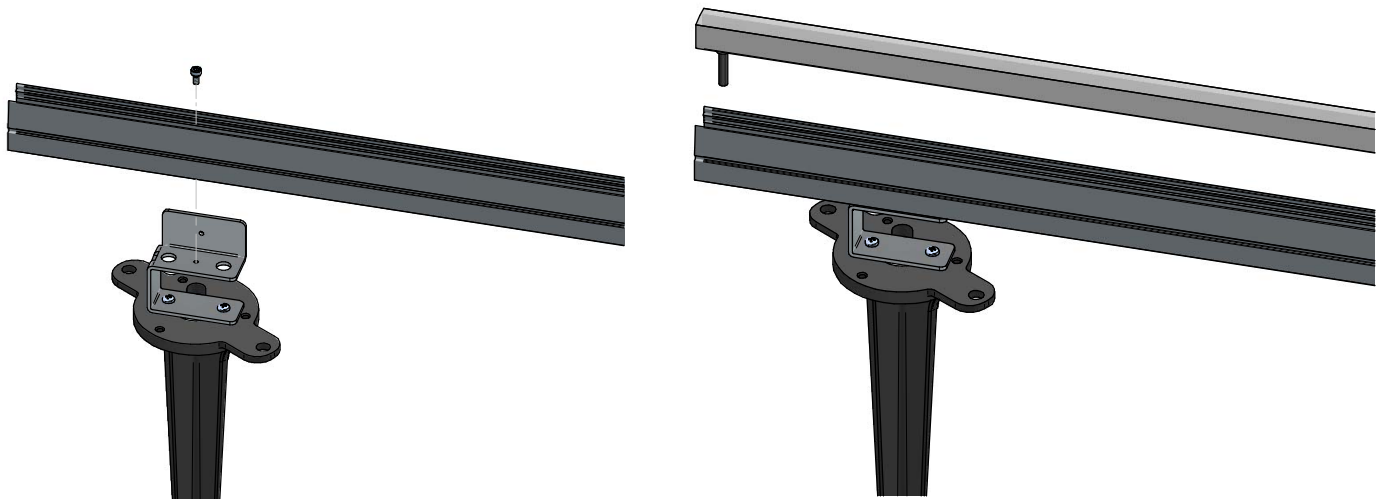

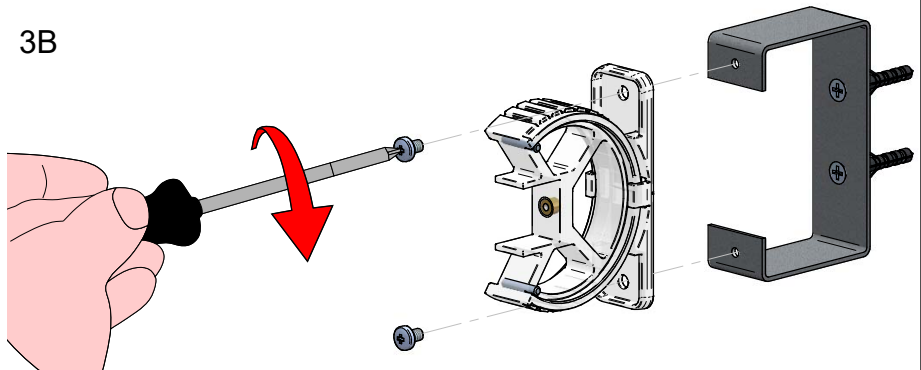
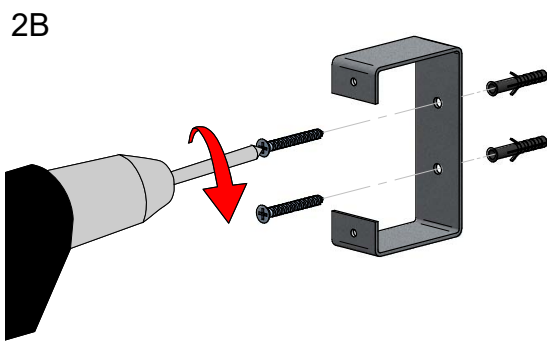
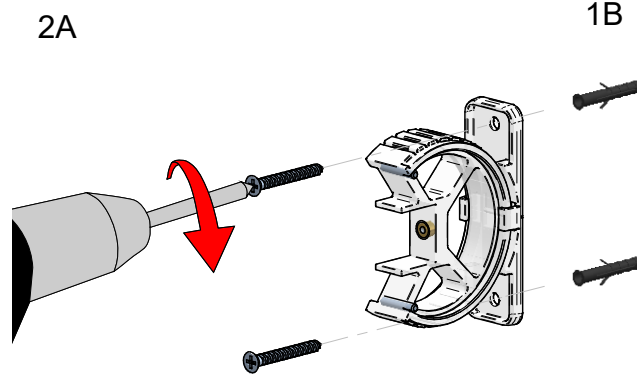
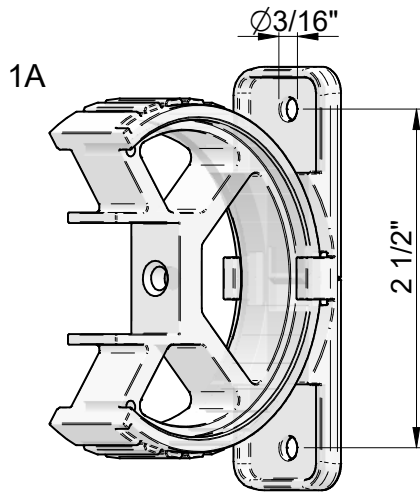
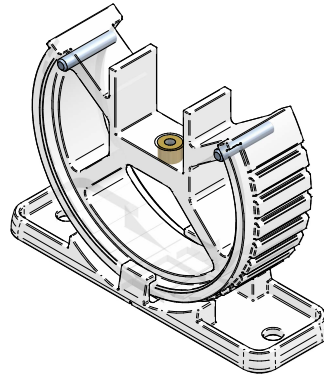
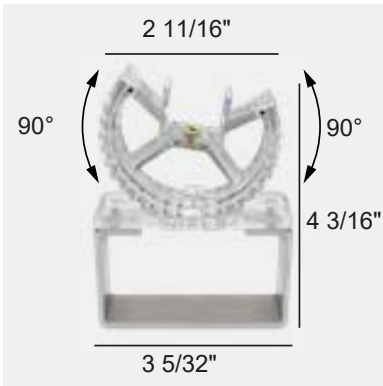
E83352 Tilting bracket

Clip without connector cavity Installation

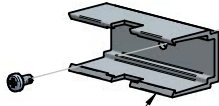
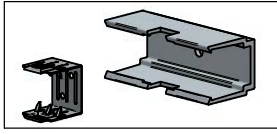

NOT INCLUDED

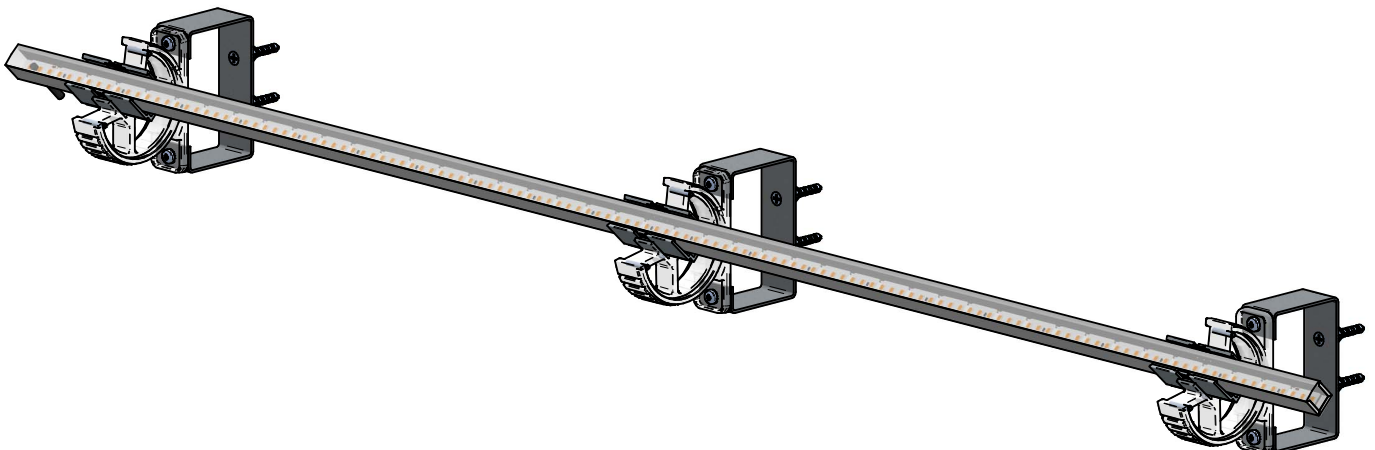
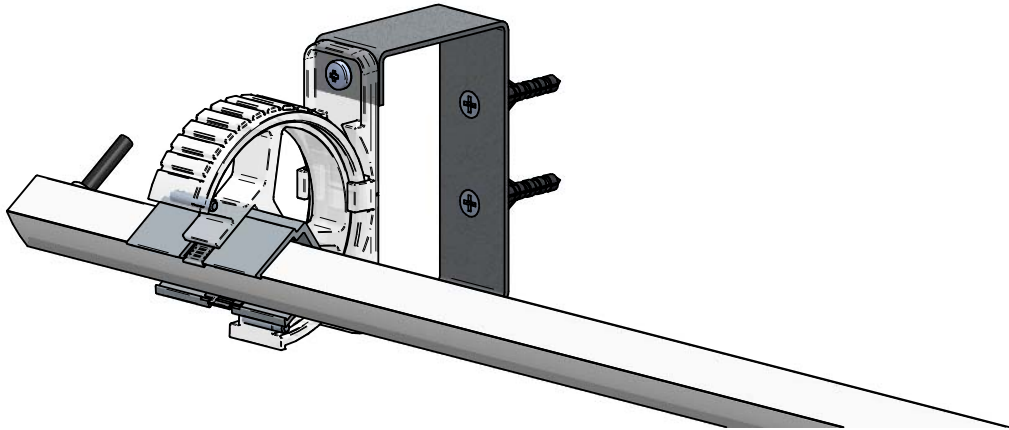
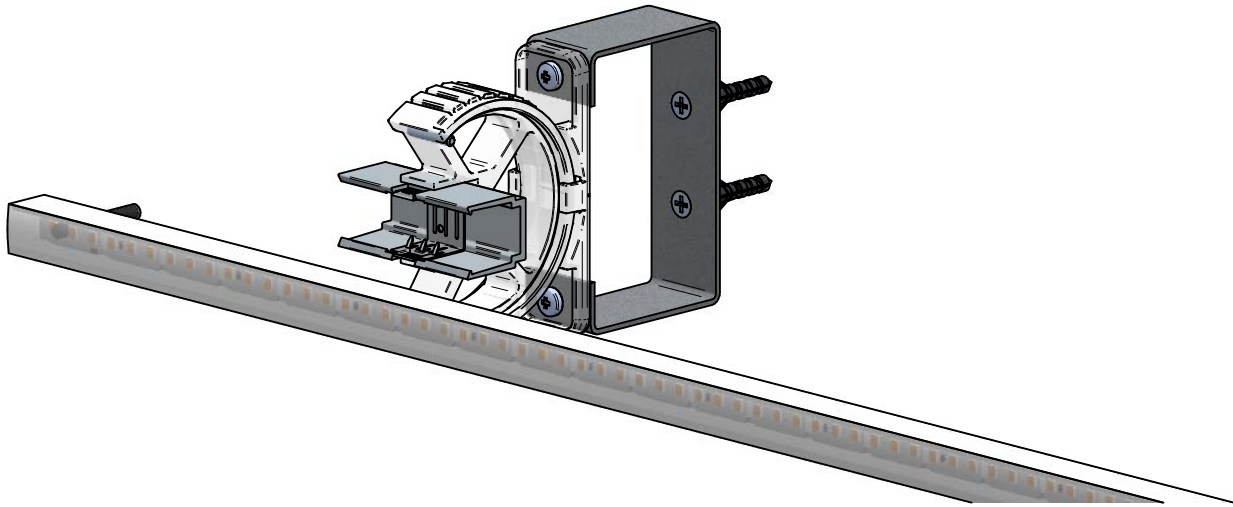
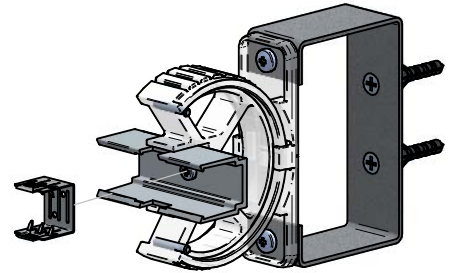
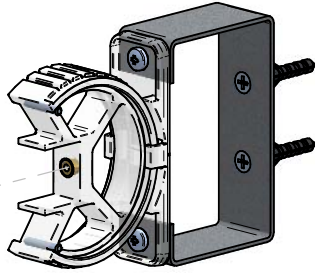

Clip with connector cavity Installation

NOT INCLUDED

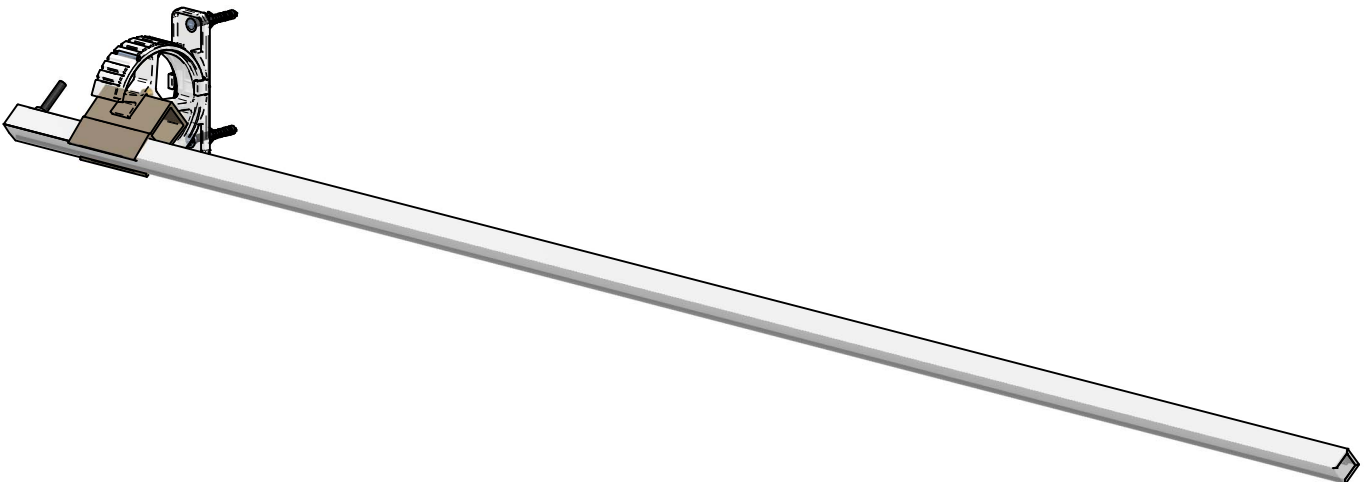
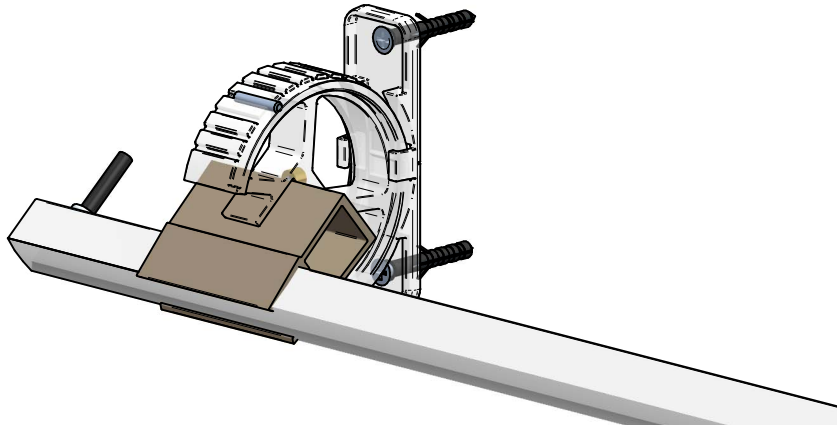
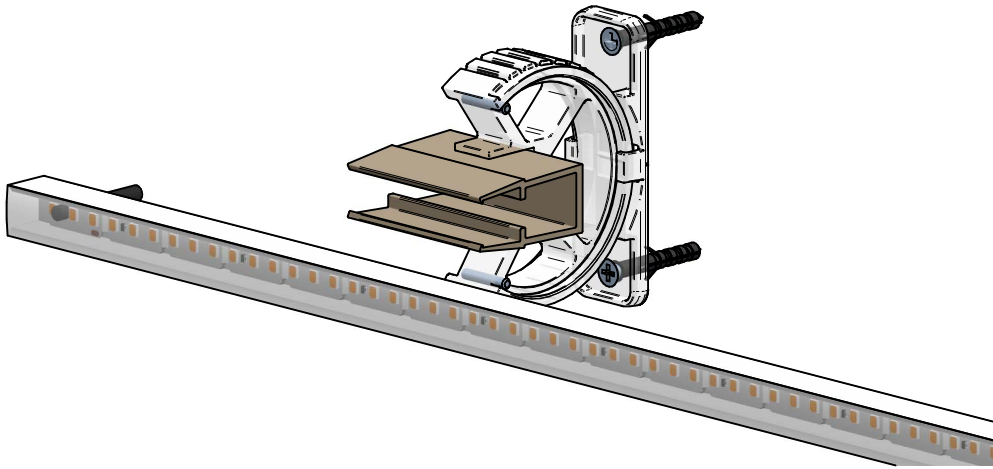
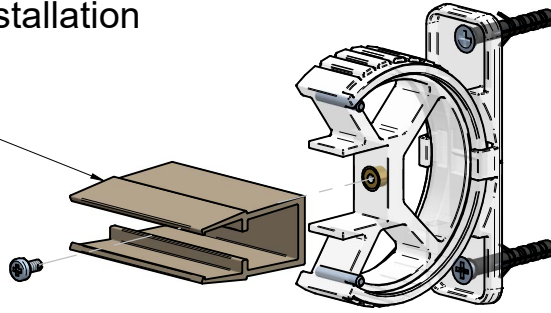

Linear profile Installation

NOT INCLUDED

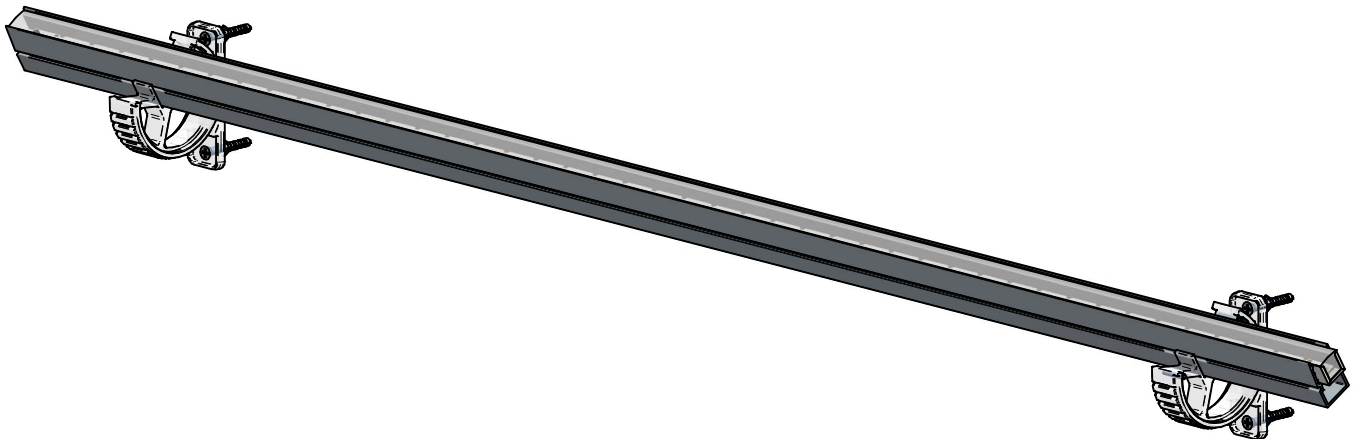
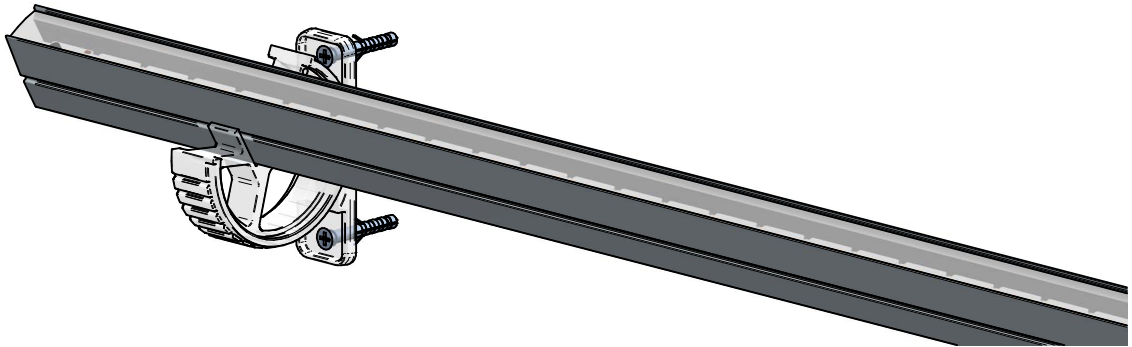
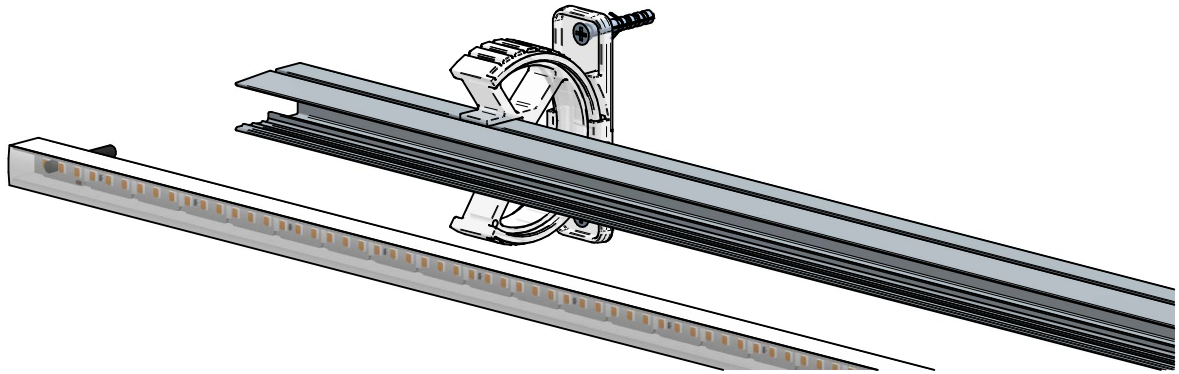
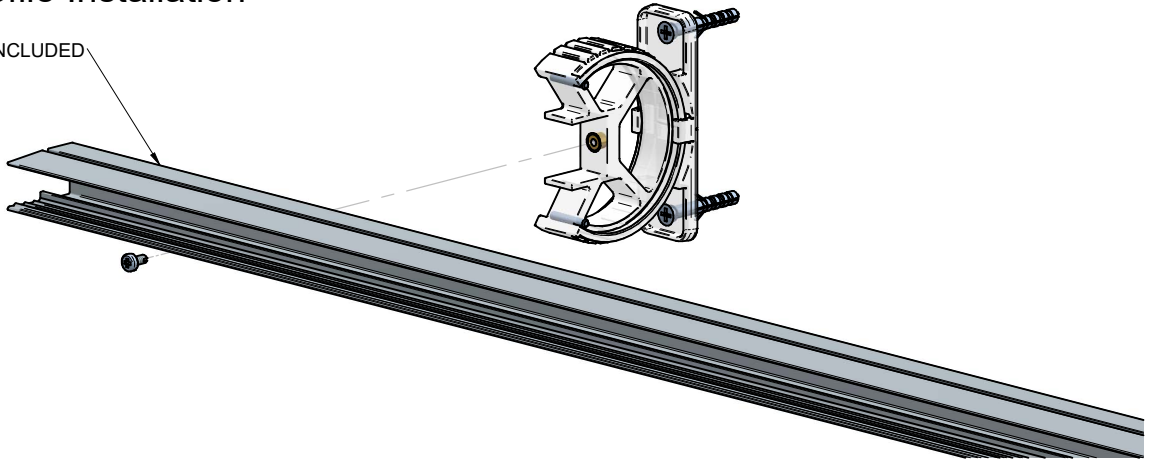

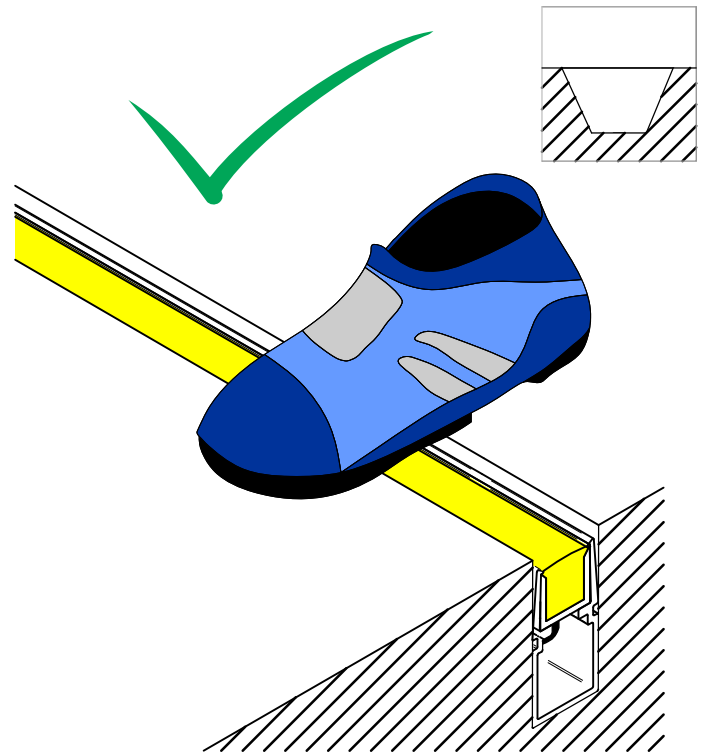
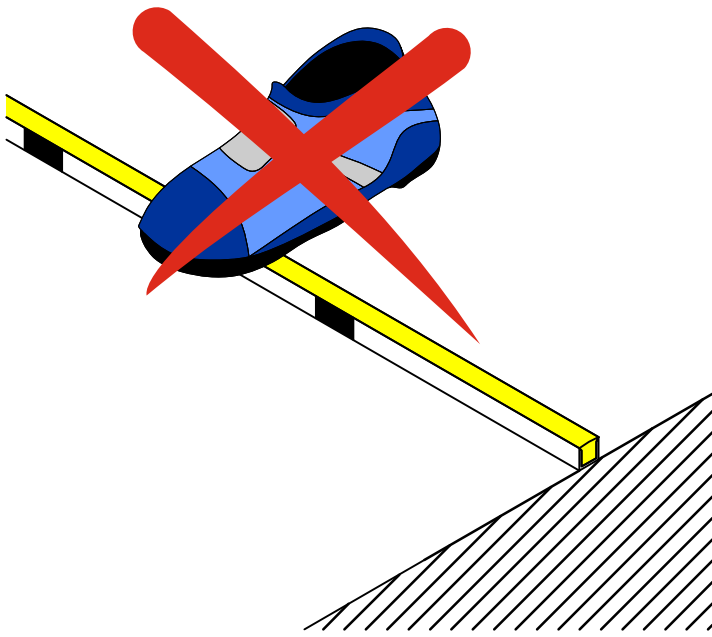
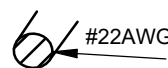
**A**
 #22AWG → L1= 78.7 inch MAX / L2= 16.4 feet MAX

96W 24VDC
CLASS 2
LED driver

E-W200002
Female connector
Feed cable (78.7")

Feed cable color scheme:
(+) White conductor
(-) Clear conductor

L1

L2

Rubber 3D

Male end cap

**Warning!**

- On continuous runs, a dedicated feed-entry point is required per driver, at the start of the first reel powered by each new driver.
- Feed cables are 78.7" long. If a longer distance to the driver is needed, the installer should plan for an appropriate splice for the application, and account for voltage drop.

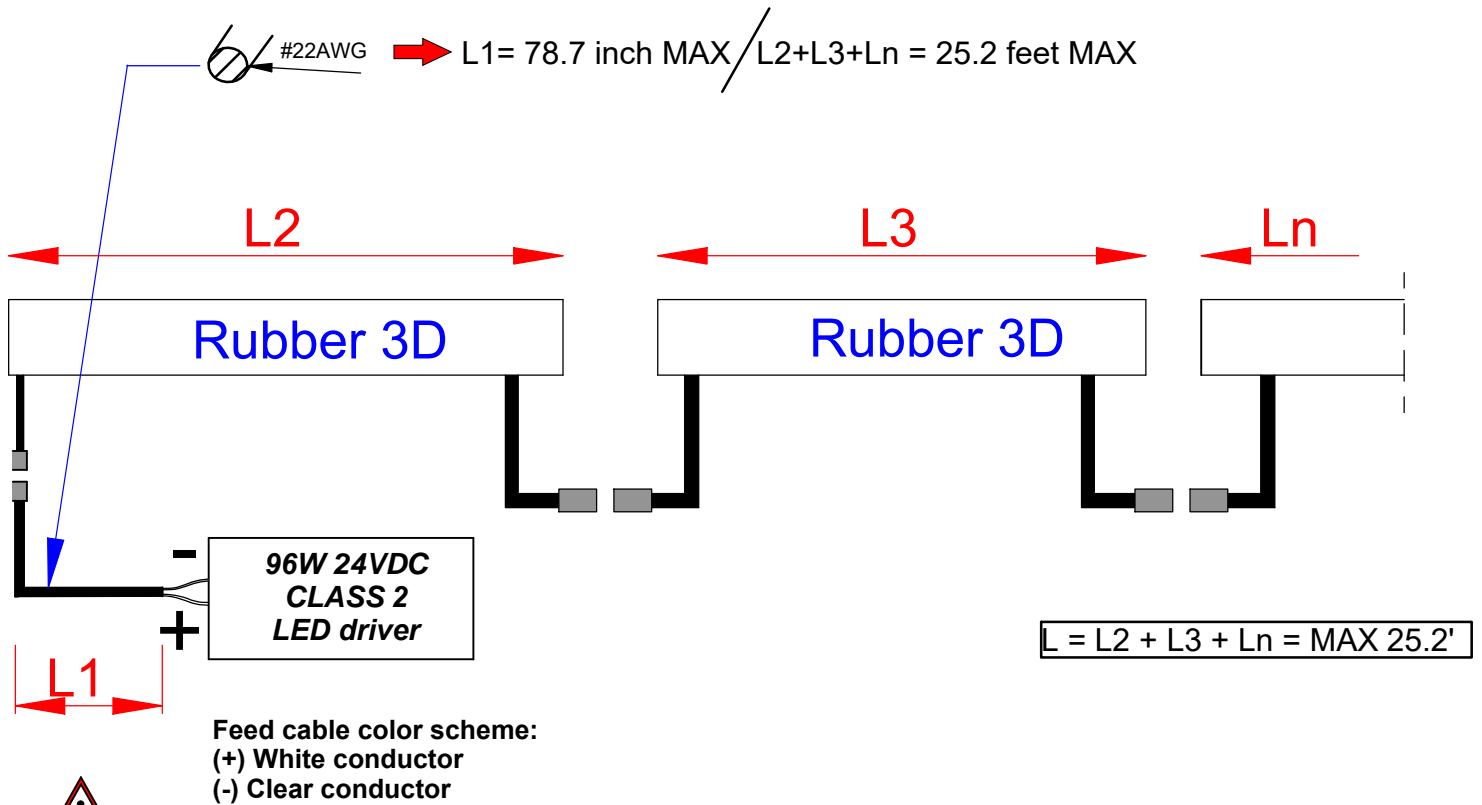
B**E-W200002**Female connector
Feed cable (78.7")**Warning!**

- On continuous runs, a dedicated feed-entry point is required per driver, at the start of the first reel powered by each new driver.
- Feed cables are 78.7" long. If a longer distance to the driver is needed, the installer should plan for an appropriate splice for the application, and account for voltage drop.

RUBBER 3D and RUBBER 3D RGBW

- A** Feed cable color scheme:
 (+) Clear conductor
 (Red -) Red conductor
 (Green -) Green conductor
 (Blue -) Blue conductor
 (White -) White conductor

#22AWG → L1 = 78.7 inch MAX / L2 = 16.4 feet MAX

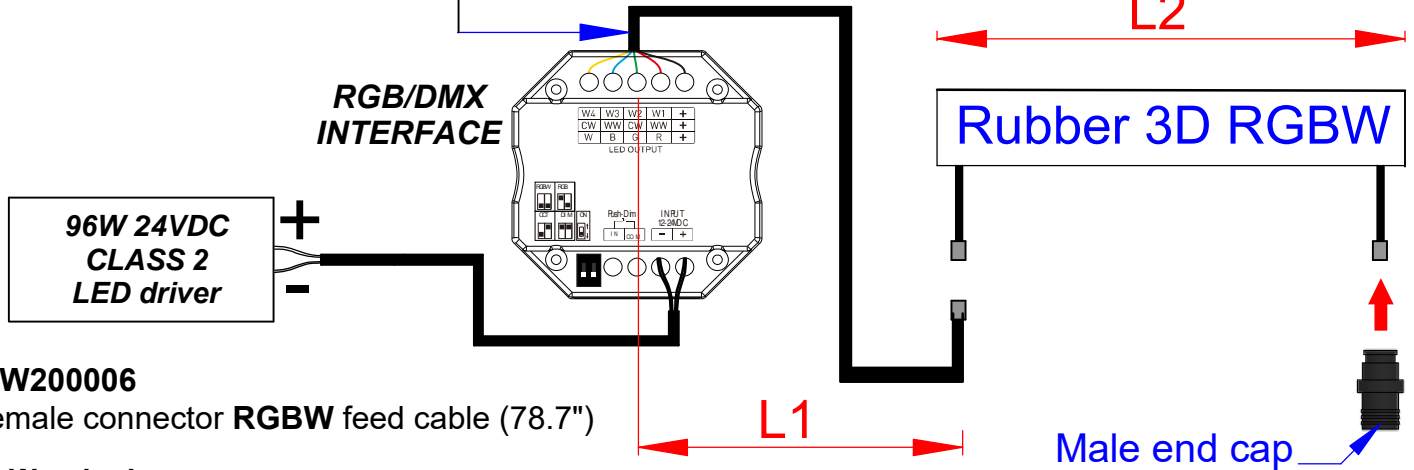

E-W200006
 Female connector RGBW feed cable (78.7")

Warning!

- On continuous runs, a dedicated feed-entry point is required per driver, at the start of the first reel powered by each new driver.
- Feed cables are 78.7" long. If a longer distance to the driver is needed, the installer should plan for an appropriate splice for the application, and account for voltage drop.

B #22AWG → L1 = 78.7 inch MAX / L2+L3+Ln = 16.4 feet MAX

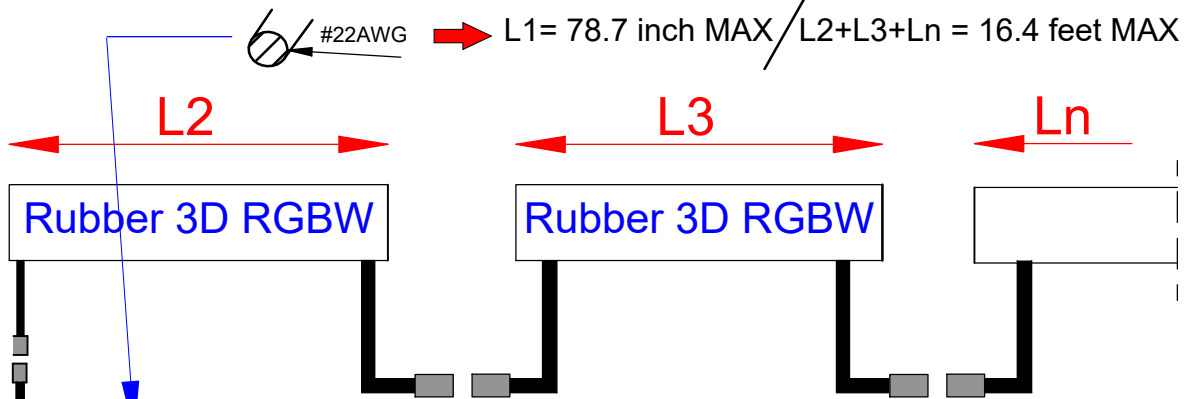

E-W200006
 Female connector RGBW feed cable (78.7")



Warning!

- On continuous runs, a dedicated feed-entry point is required per driver, at the start of the first reel powered by each new driver.
- Feed cables are 78.7" long. If a longer distance to the driver is needed, the installer should plan for an appropriate splice for the application, and account for voltage drop.

- Feed cable color scheme:
 (+) Clear conductor
 (Red -) Red conductor
 (Green -) Green conductor
 (Blue -) Blue conductor
 (White -) White conductor

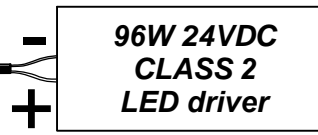

$L = L2 + L3 + Ln = \text{MAX } 16.4'$

Feed cables (Ordered separately)**Rubber 3D****E-W200002**Feed Cable 78.7"
2x#22AWG
with 2 pole female
connector**E-W200001**Feed Cable 78.7"
2x#22AWG
with 2 pole male
connector**Rubber 3D RGBW****E-W200006**RGBW Feed Cable
78.7" 5x#22AWG
with 5 pole female
connector**E-W200005**RGBW Feed Cable
78.7" 5x#22AWG
with 5 pole male
connector