

IMPORTANT: Fixture(s) must be wired in series! Refer to driver wiring document

Luminaires must be installed by a qualified electrician. Check with local and national codes for proper installation.



To prevent electrical shock disconnect electrical supply before installation or servicing.

Never connect a live fixture!!!

Contractor is responsible for adequately reinforcing walls and/or ceilings to support fixture weight. Provide blocking when necessary.

For Accessible Ceilings Only*

Remote Driver

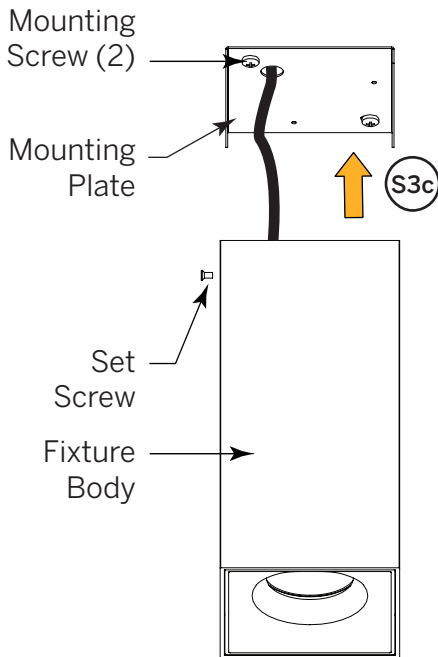

Step 1

Confirm Power Supply is Off!

Unpack luminaire unit. Remote drivers and housings are supplied by Inter-lux.

Step 2

Ceiling Preparation

Mark location and drill hole for cable pass-through

IMPORTANT: Note that hole in Mounting Plate is not at center

Step 3

Mount Luminaire

- Secure Mounting Plate to ceiling with Mounting Screws or anchors. Use backing material if necessary.
- Feed all cables from fixture through hole in Mounting Plate.
- Slip Fixture Body over Mounting Plate. Secure with Set Screw.

Step 4

Electrical Connection

Above ceiling, connect power (and control) wire(s) to Remote Driver.

Included in Box

- (1) Fixture Body with connected cable
- (1) Mounting Plate
- (2) Mounting Screws
- (1) Set Screw

Please find full-size installation template on next page

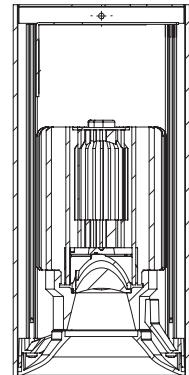

Cross-Section of Fixture

*Alternatively, wire or cable may be fed from an accessible driver to the fixture in a non-accessible ceiling.

Need Help?

Installation Template

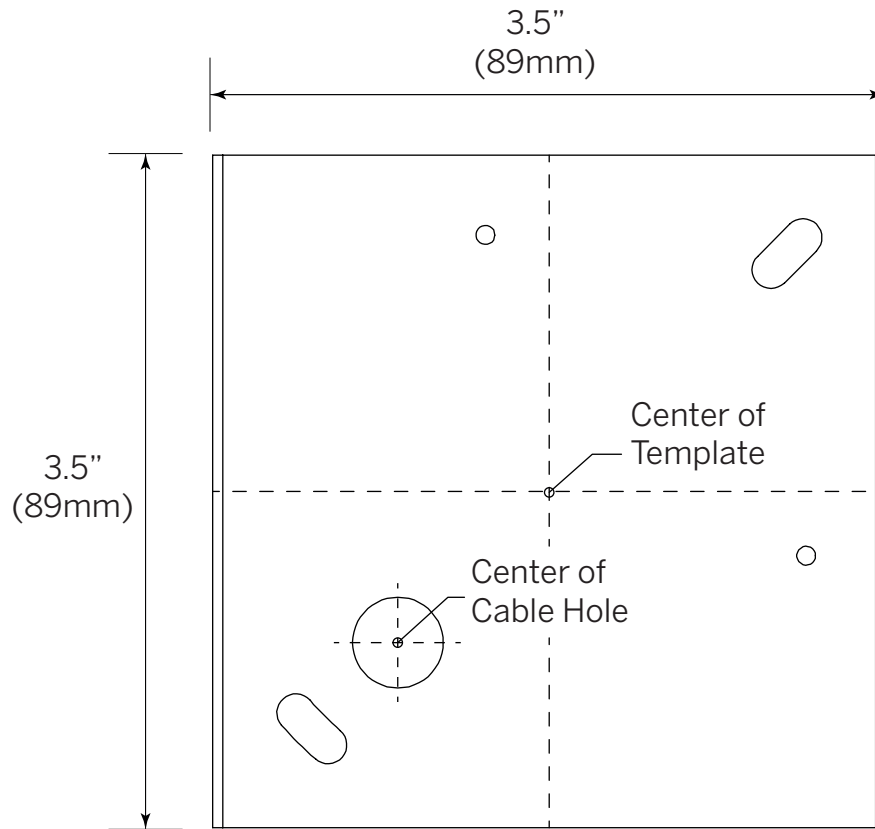

To Use:

- a** Glue this page or a photocopy to a piece of stiff cardboard or flashing
- b** With a small bit (e.g. 3/32"), drill center hole and center of Cable Hole
- c** Using a knife and straight edge, carefully trim perimeter of square
- d** Use center holes to mark locations of multiple fixtures along a center line. Trace around template to assist with keeping housings square to each other.

Need
Help?